

What's inside an electric car

Prof. Dr. Pavol Bauer, Delft University of Technology

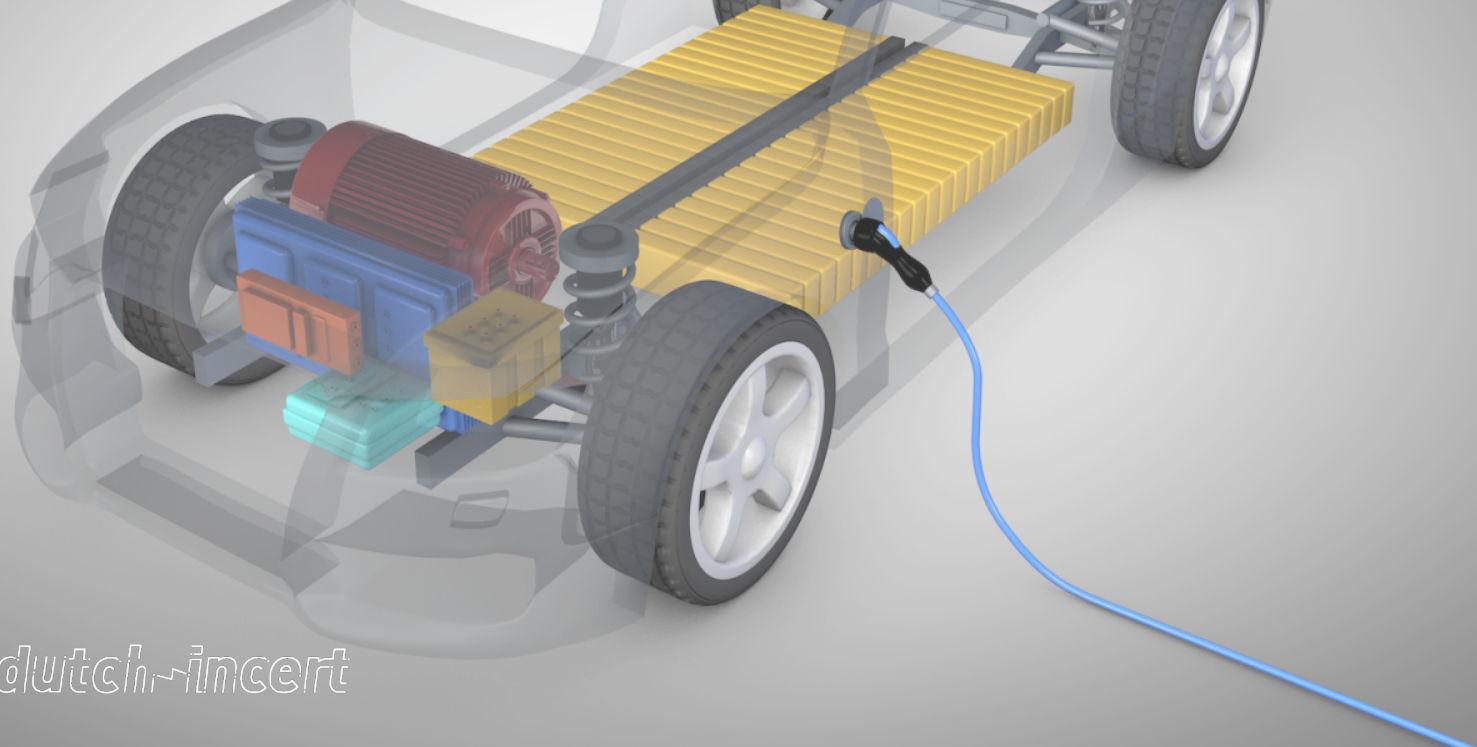

Key parts of an electric car

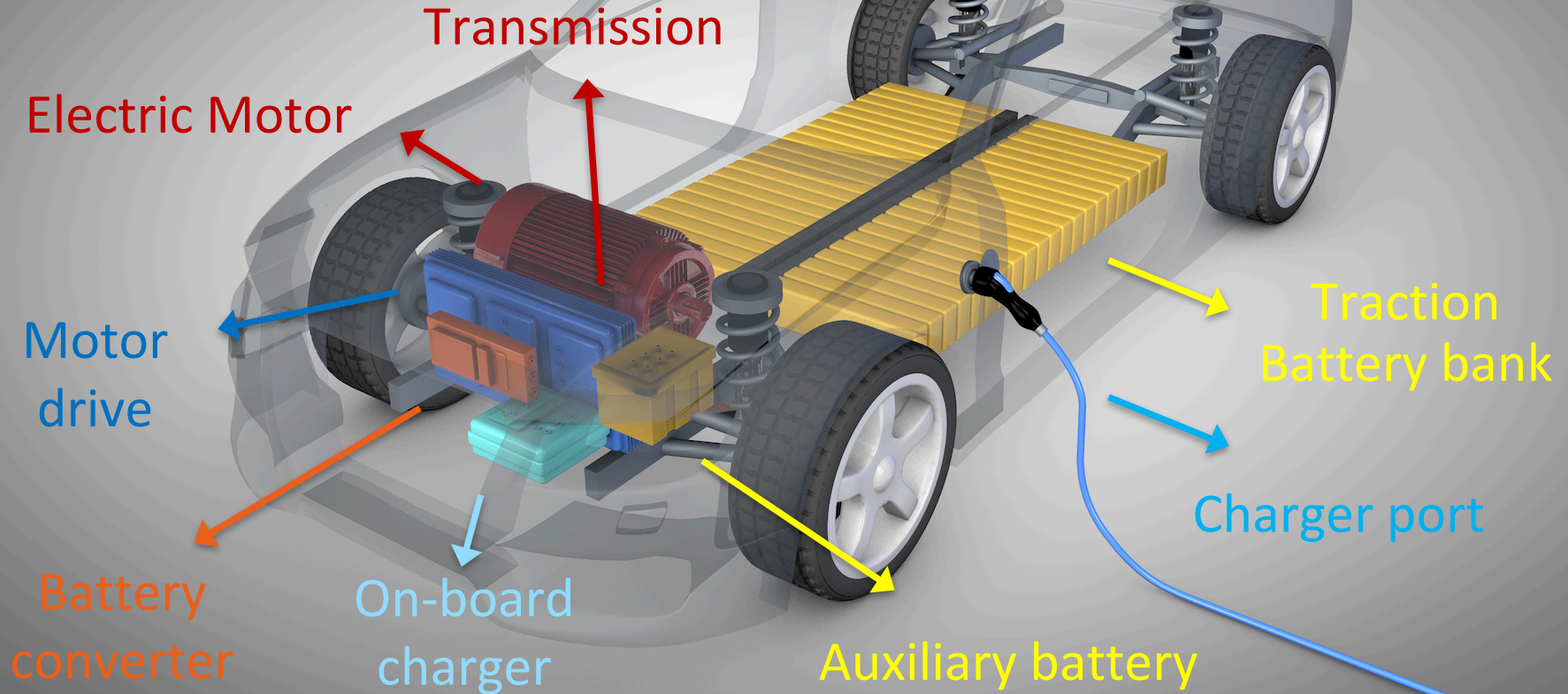

Key parts of an electric car

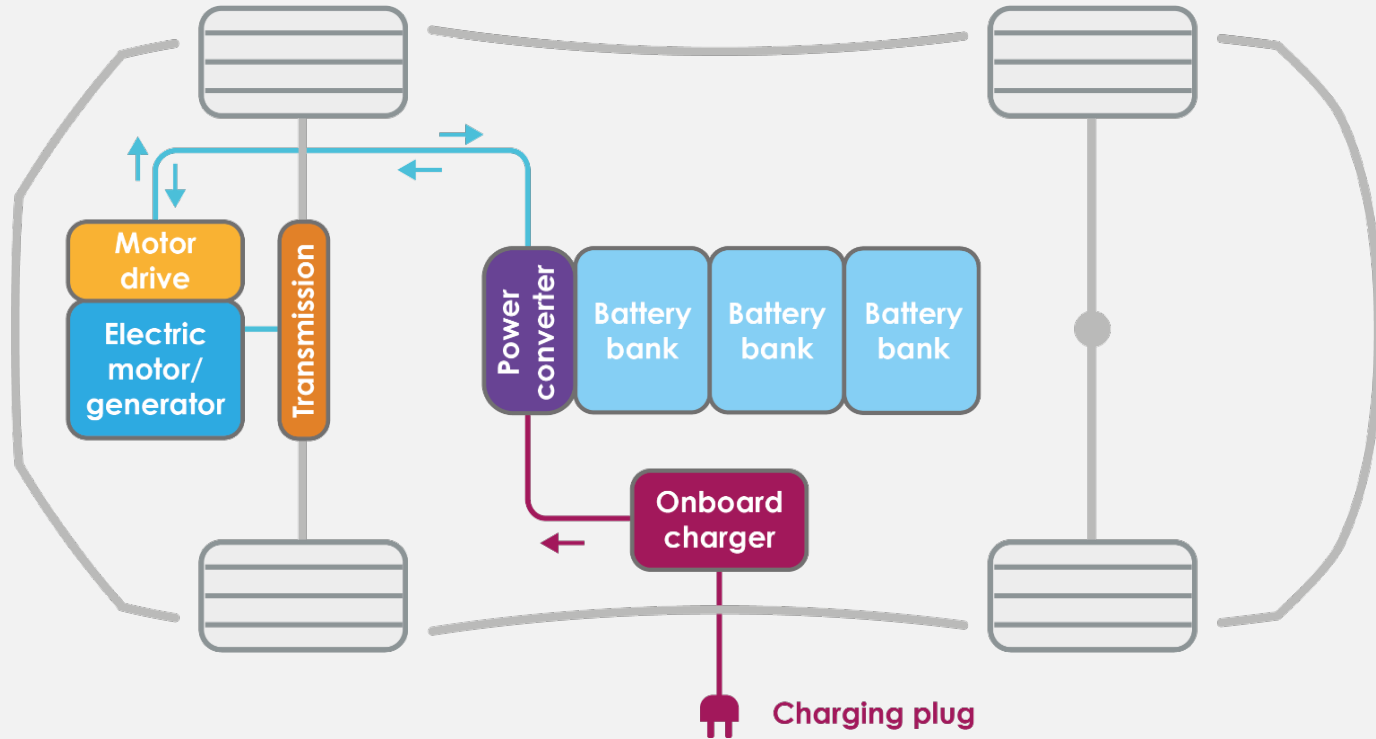

Charging port + connector + cable

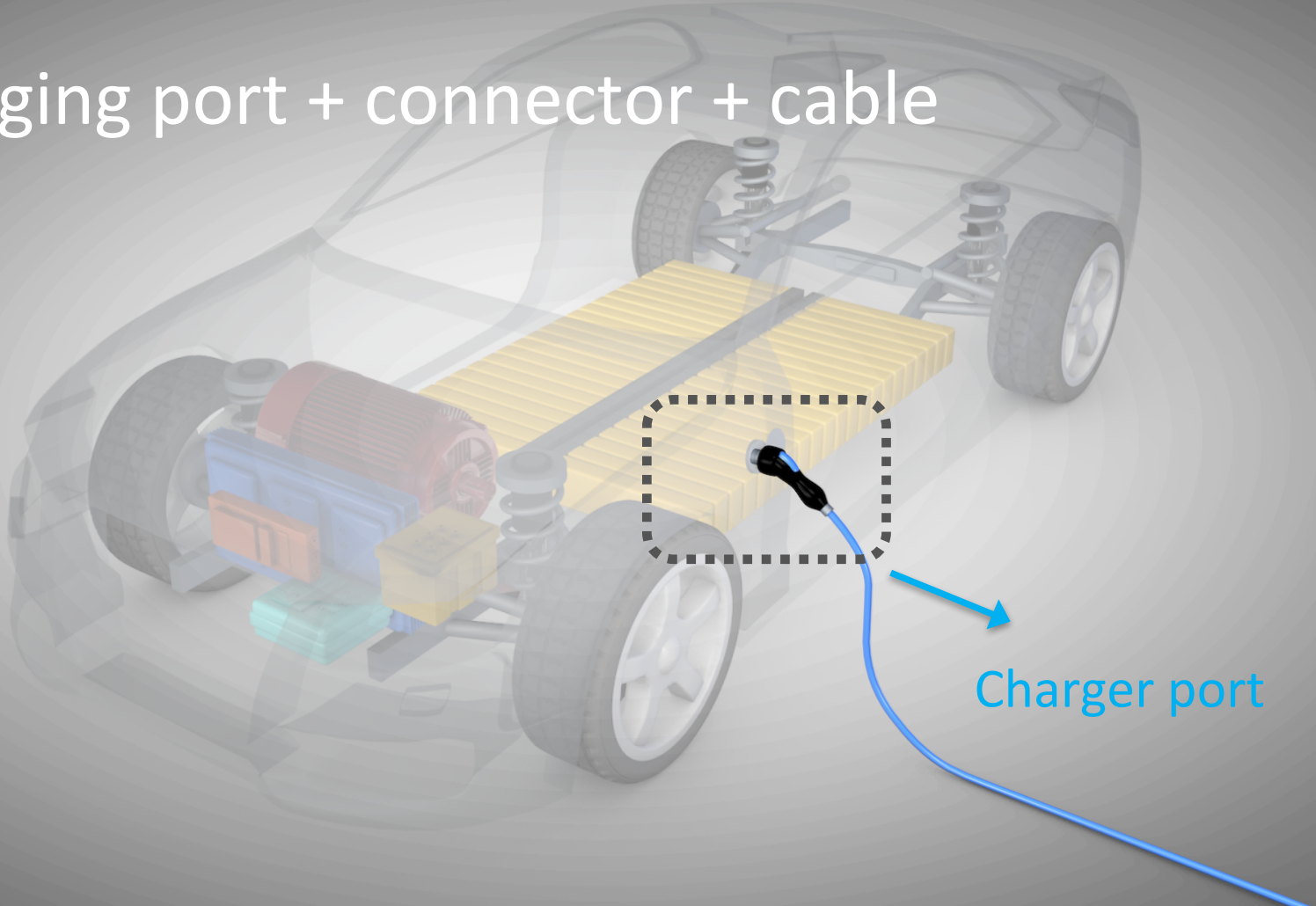

Charger port

Charging port + connector + cable

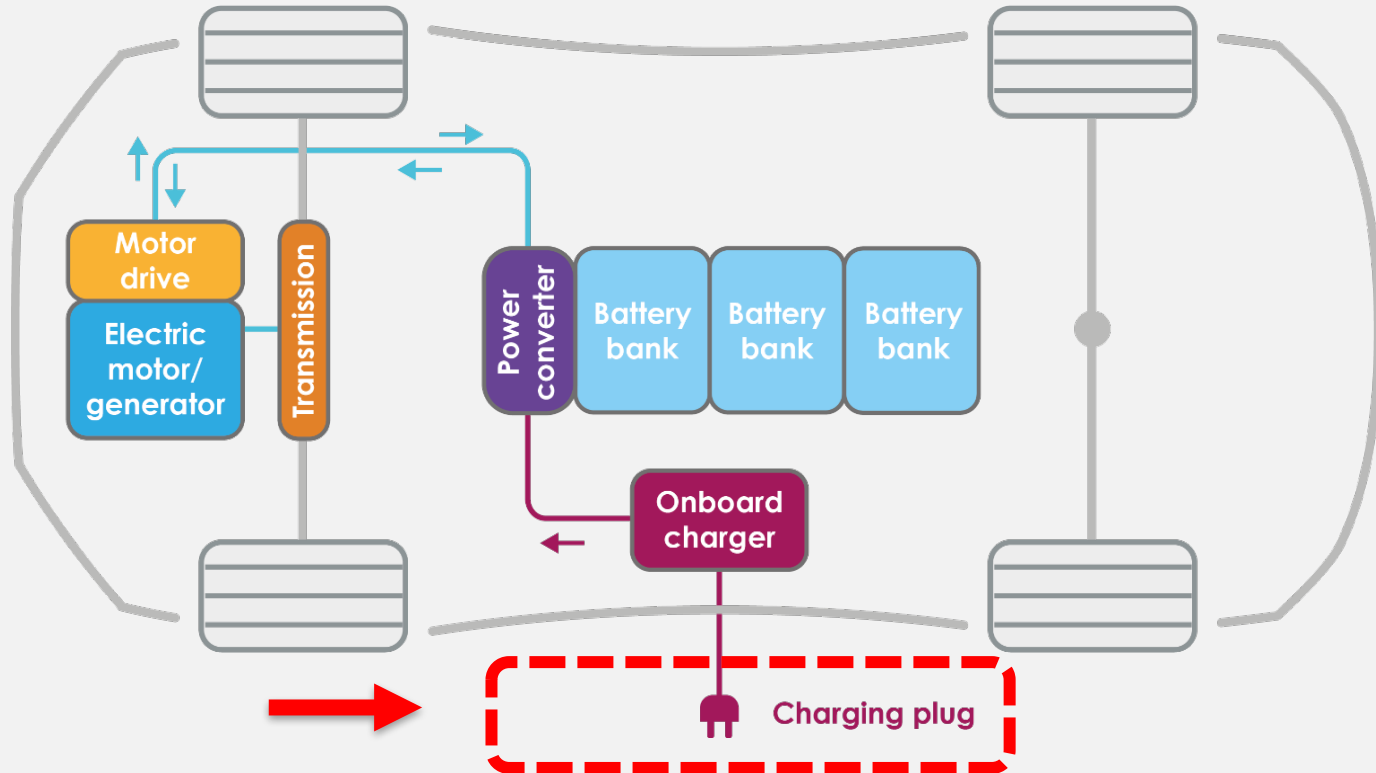

Onboard charger

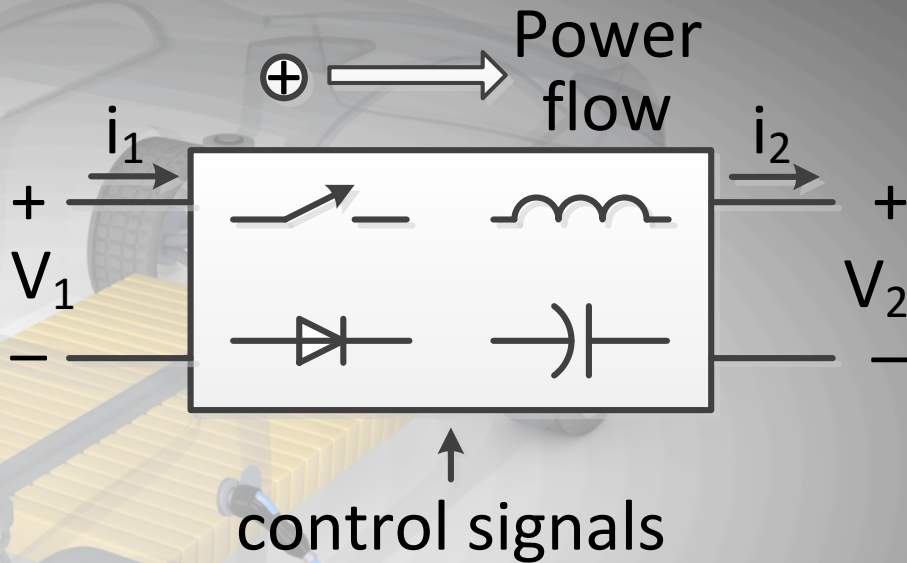

On-board
charger

Onboard charger

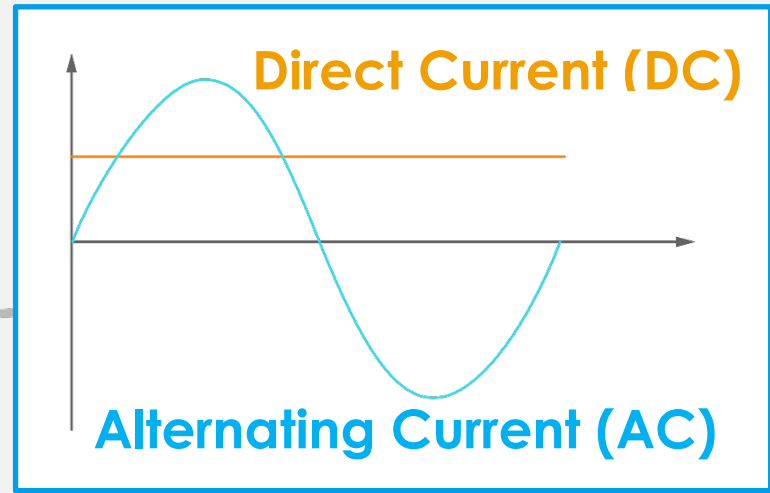
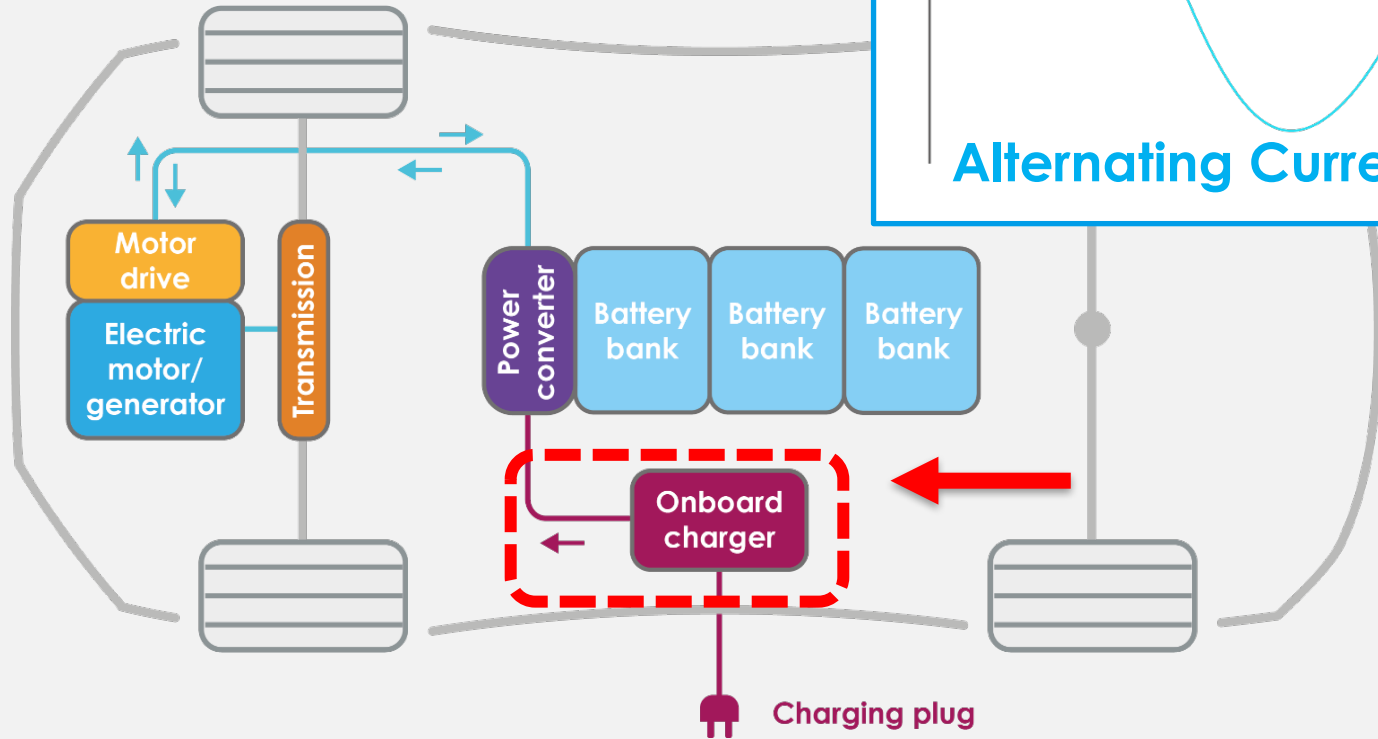

Traction battery bank

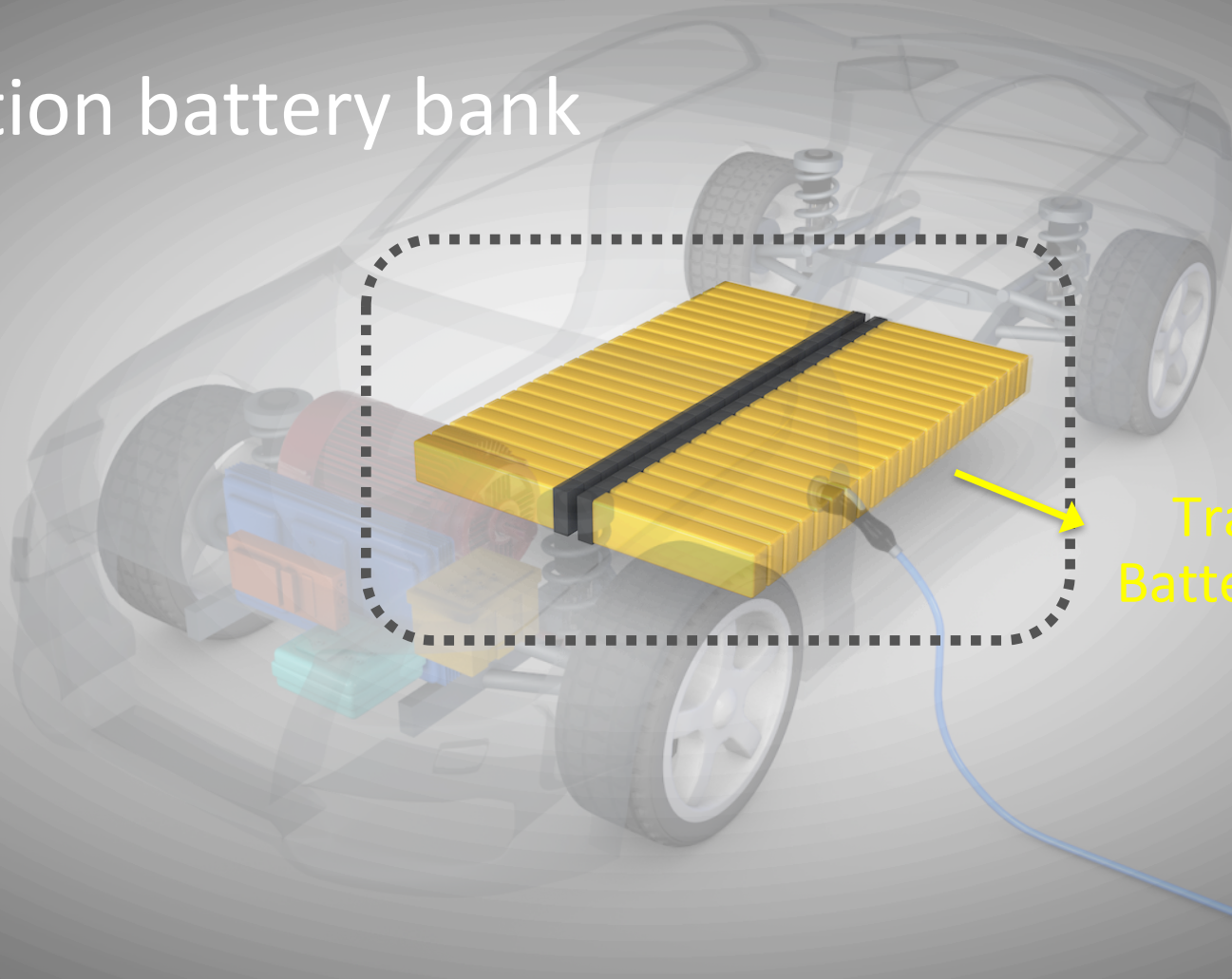

Traction
Battery bank

Traction battery bank

- Battery management system
 - Typically 10-100 kWh

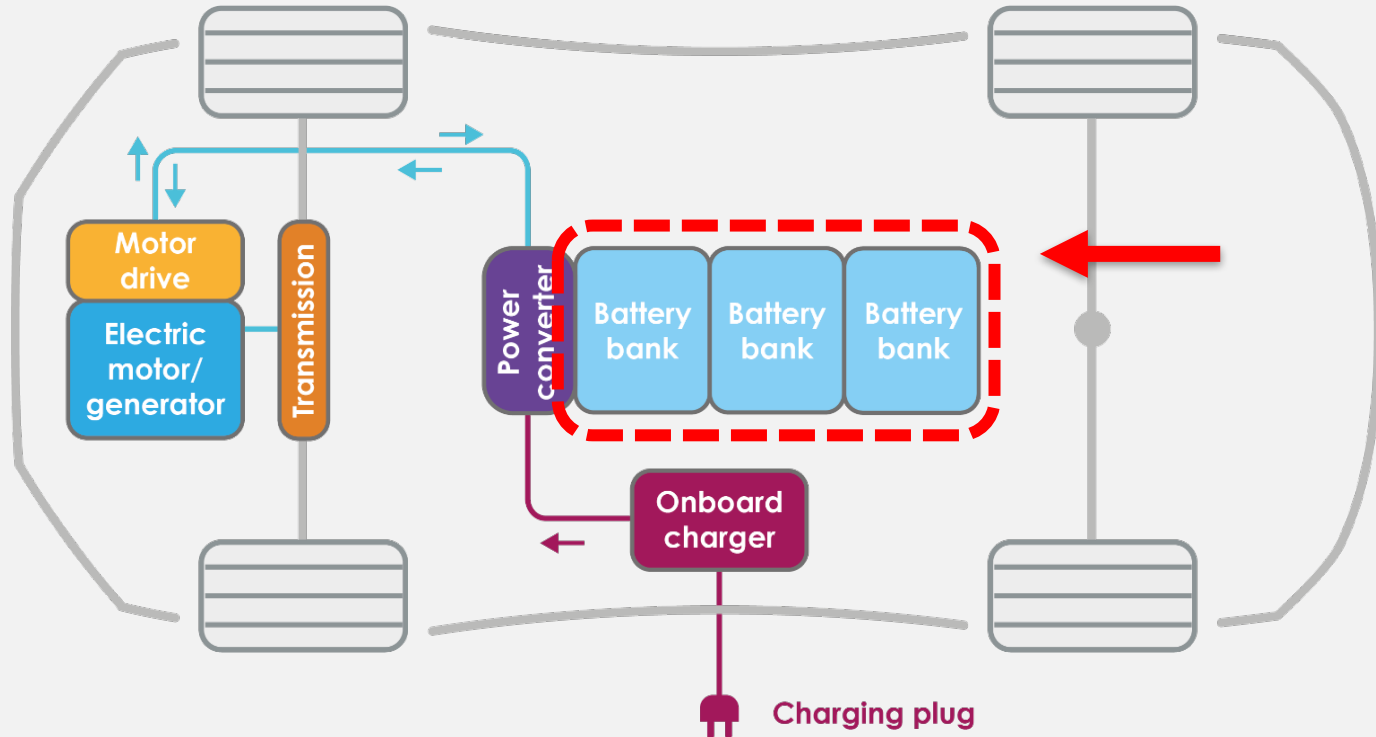

Battery types

- Lead acid
- Nickel based: NiMH, NiCd
- Lithium based :
 - Lithium-ion (Li-ion) and
 - Lithium-polymer (Li-poly)

Weight of 20kWh battery

Lead acid	550 kg
Nickel Cadmium	500 kg
Nickel Metal Hydride	350 kg
Lithium Ion	180 kg

Battery power converter

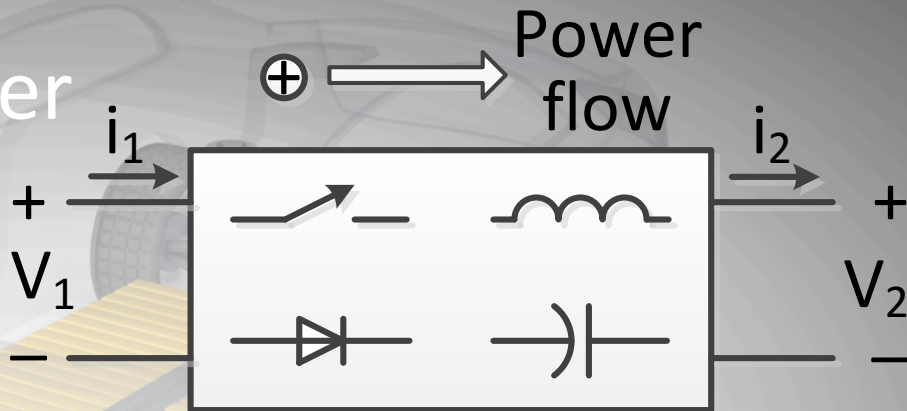

control signals

Battery
converter

Battery power converter

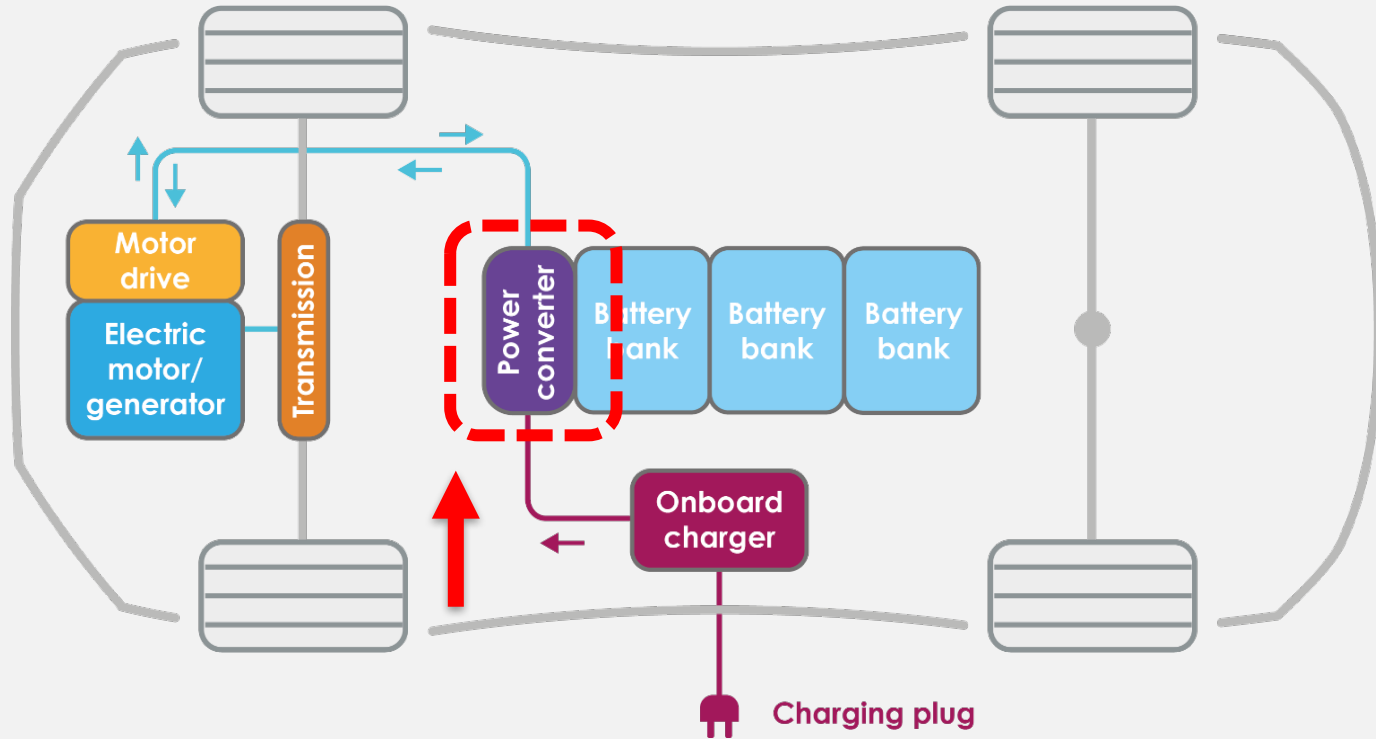

Motor drive

Motor
drive

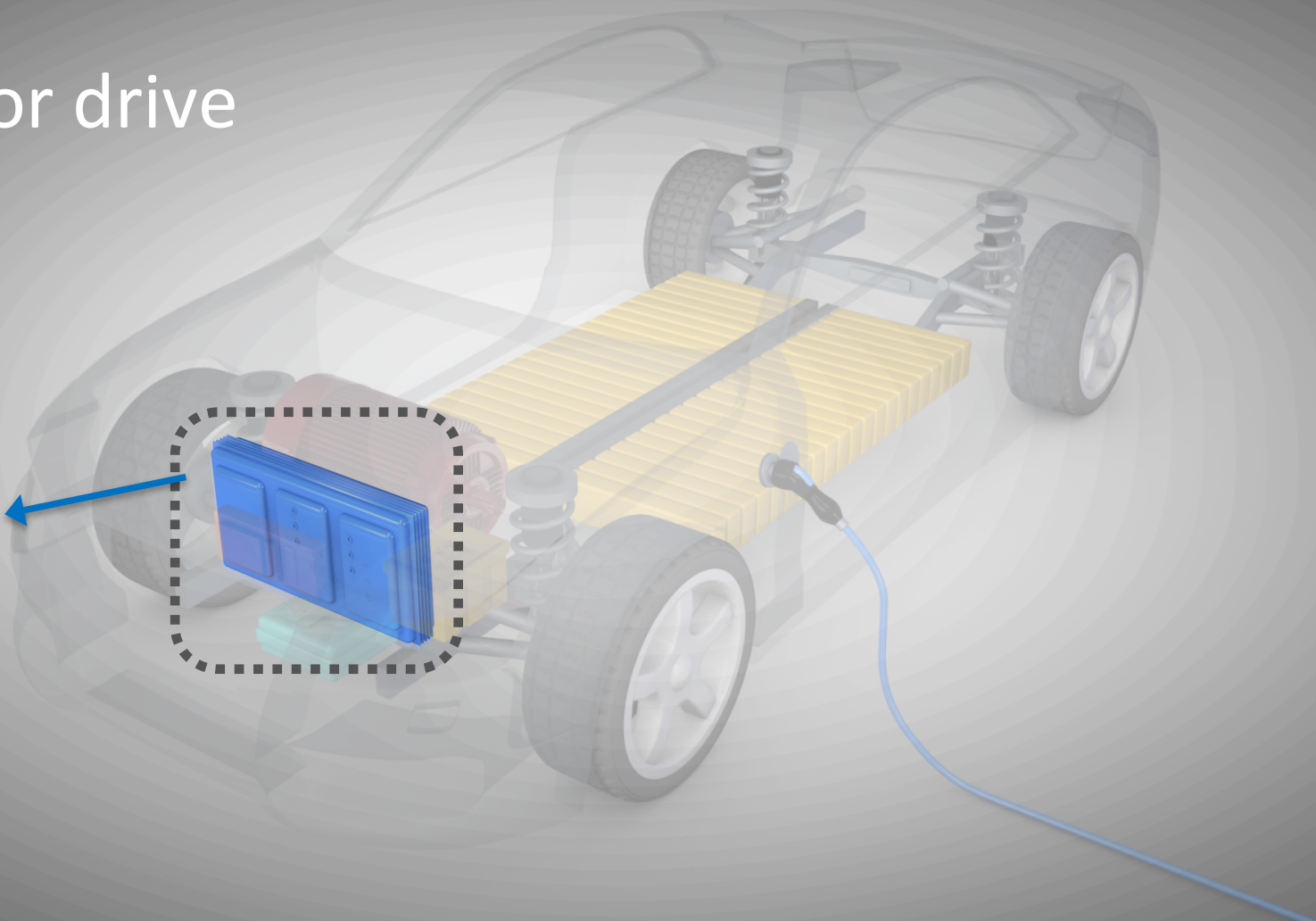

Motor drive

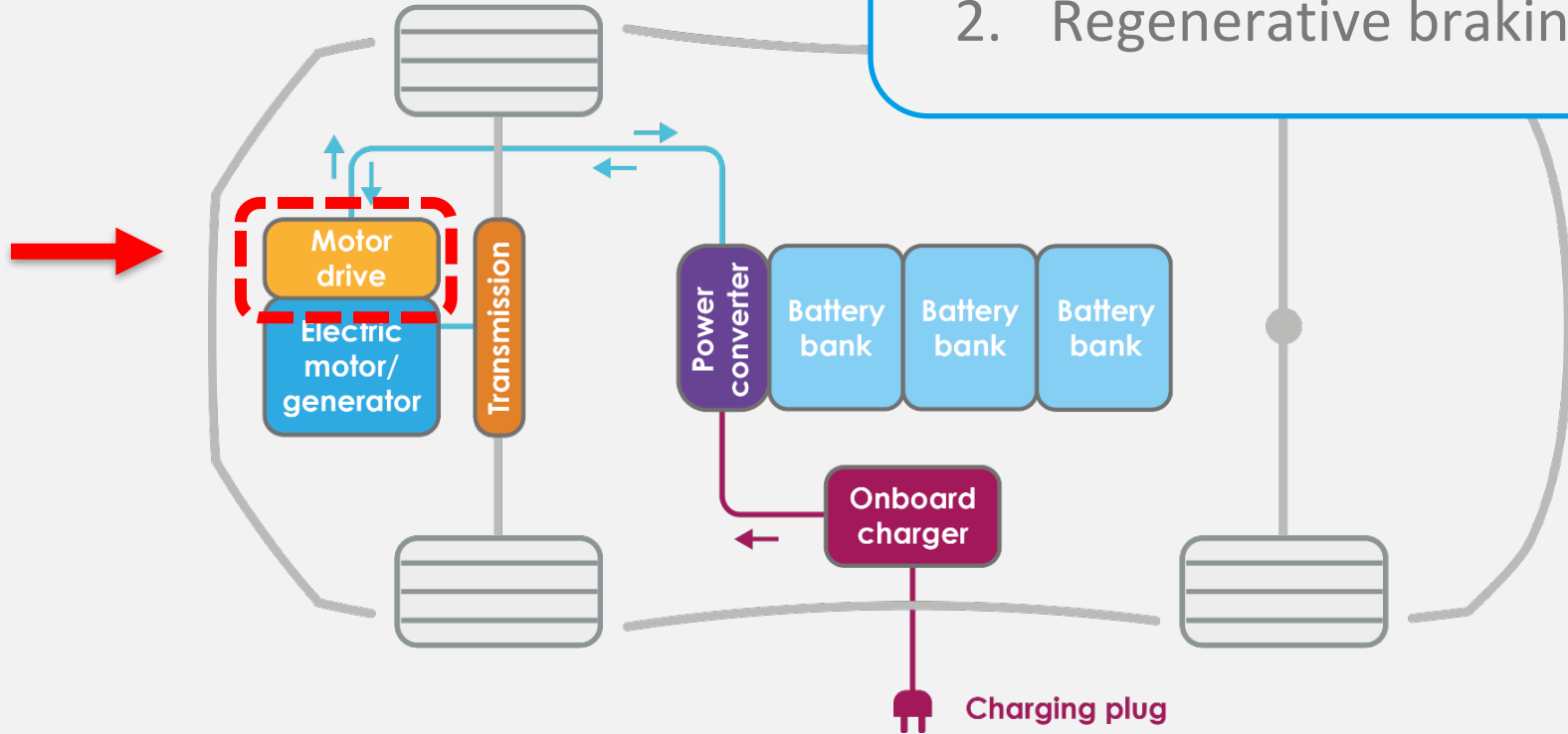

Bidirectional:

1. Driving mode
2. Regenerative braking mode

Electric Motor

Transmission

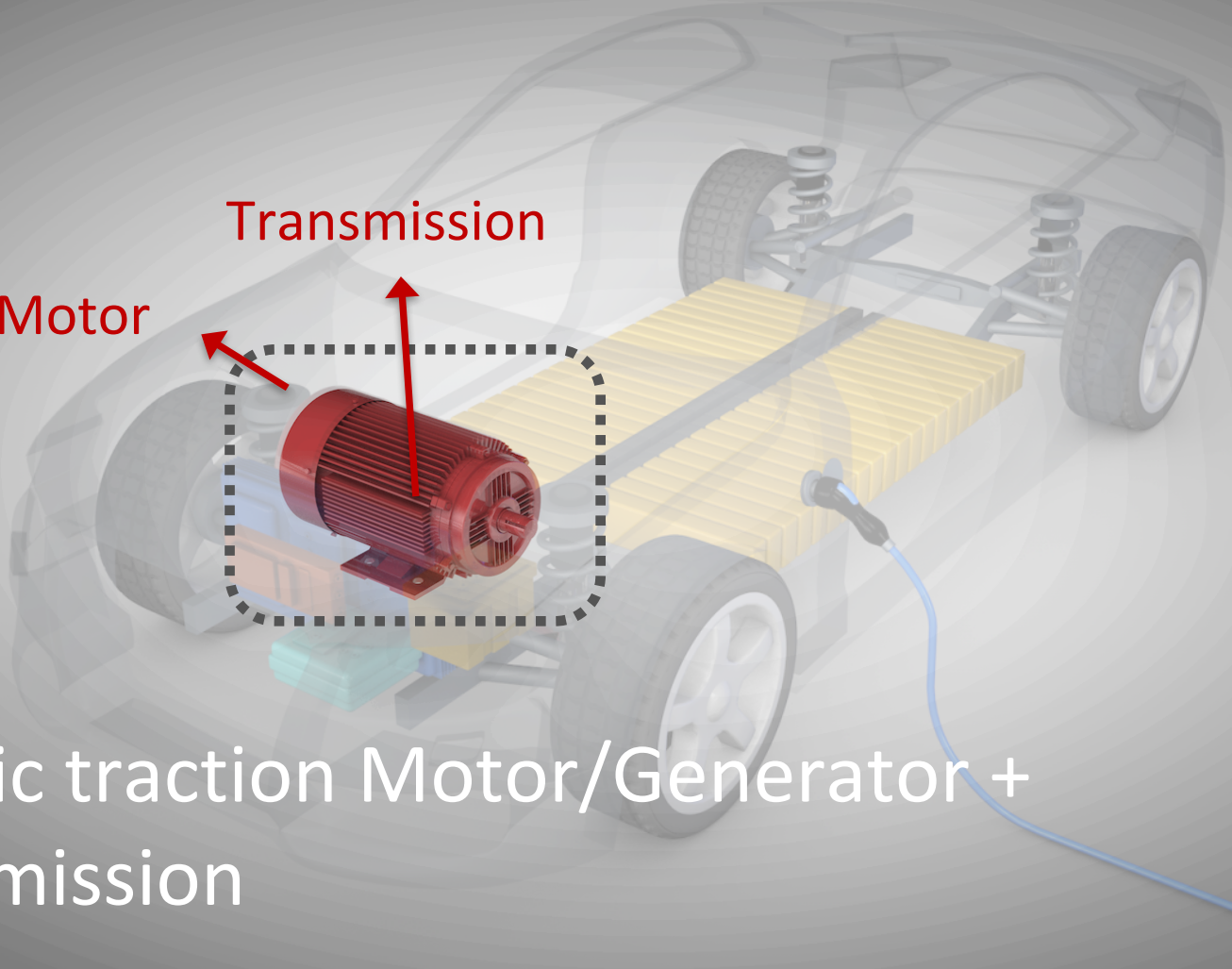

Electric traction Motor/Generator +
Transmission

Electric Motor/Generator + Transmission

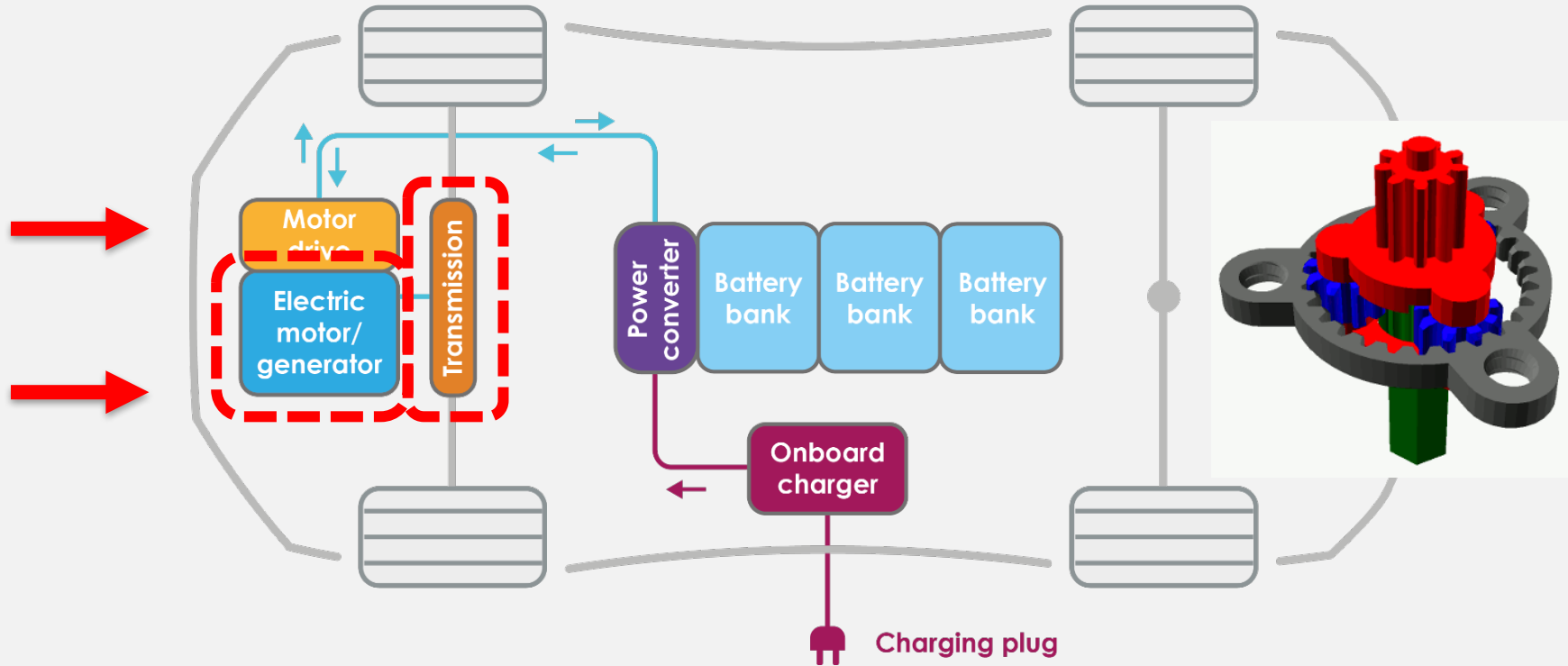

Commonly used electric motor types

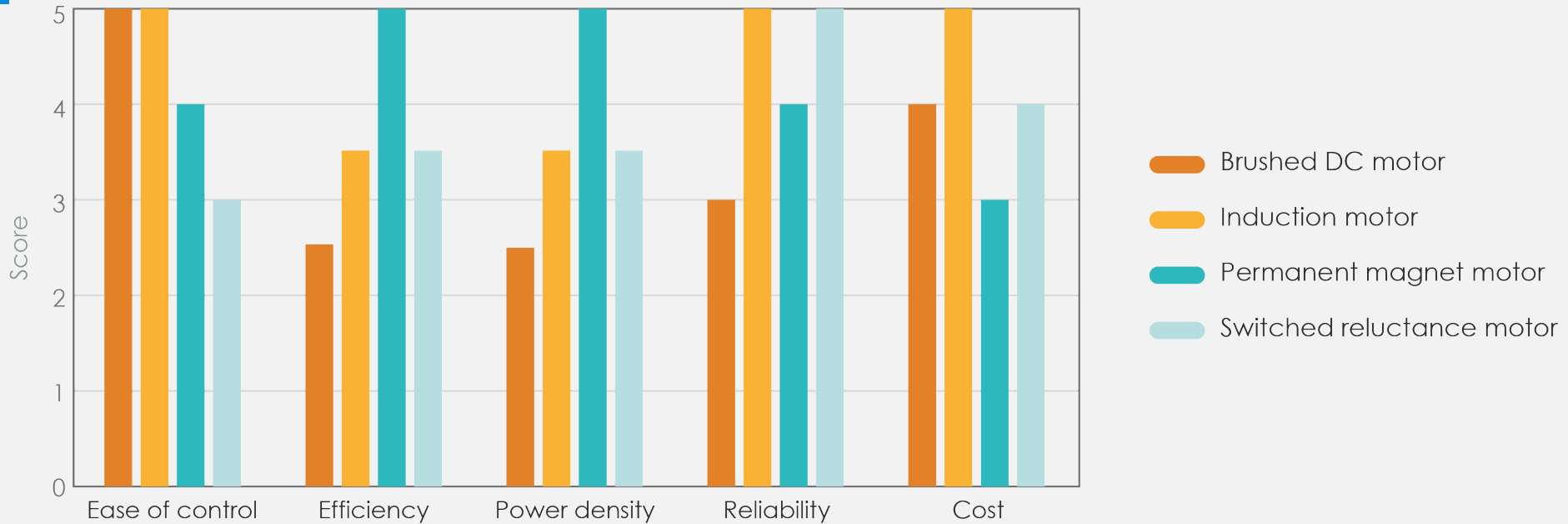

Key parts of EV

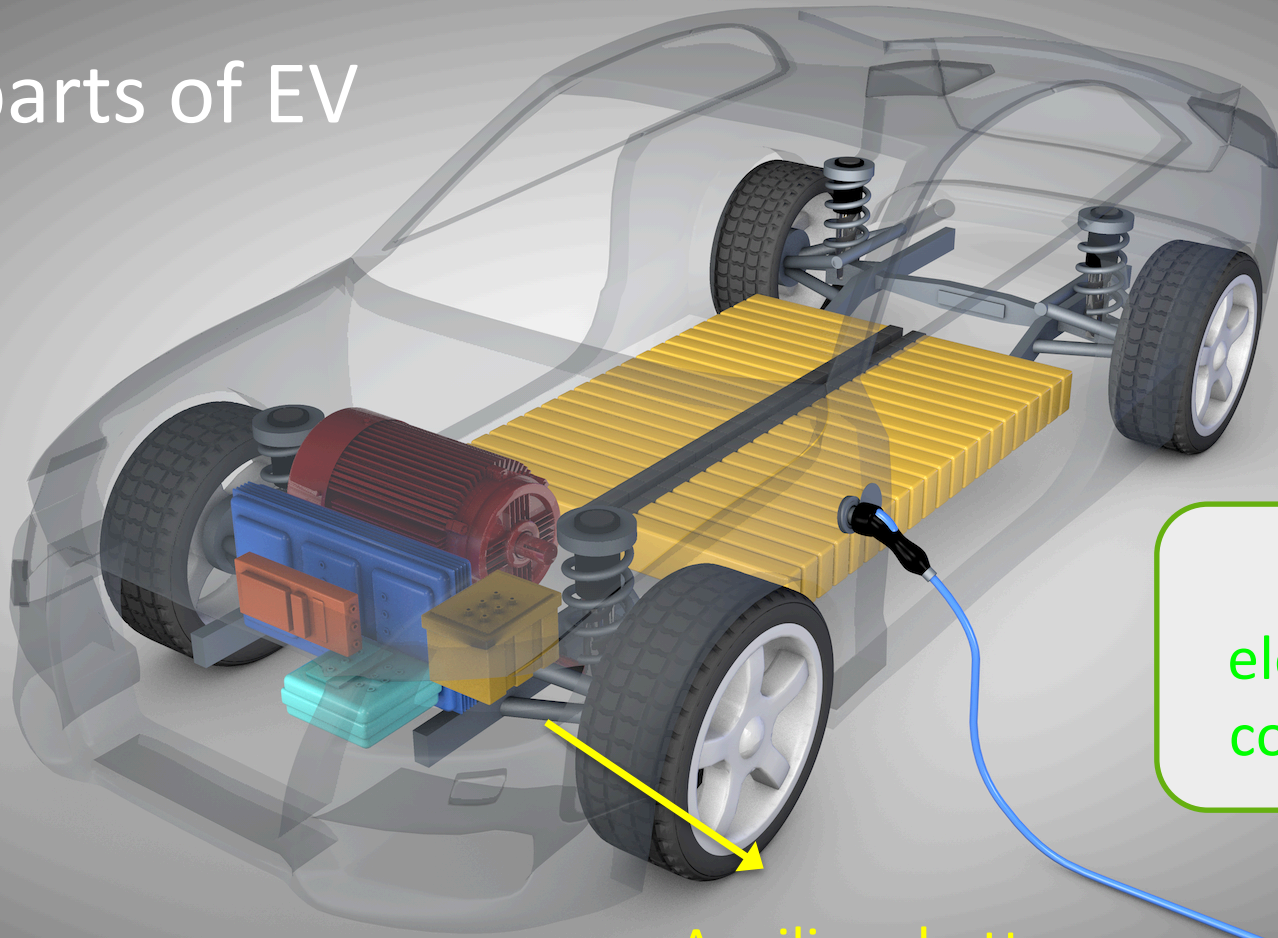

Power
electronic
controller

Auxiliary battery



Electric car: Power flow

Electric car: Power flow

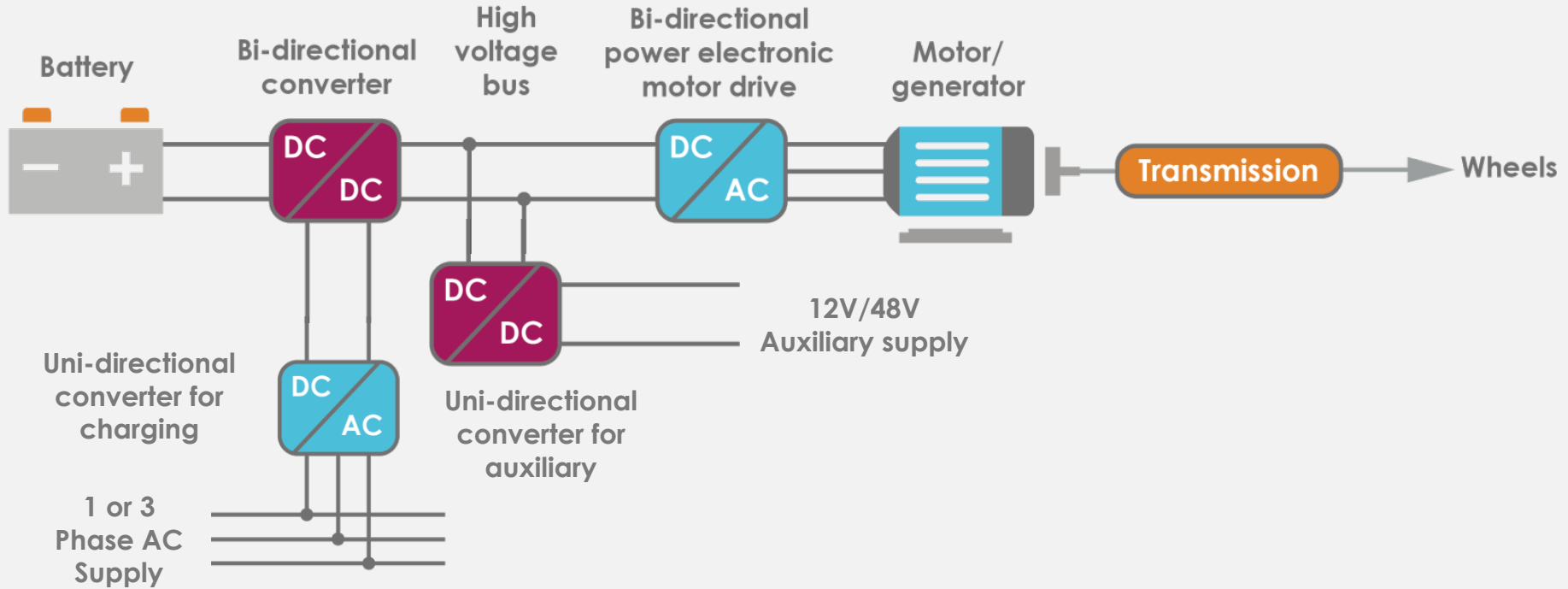

Electric car: Power flow

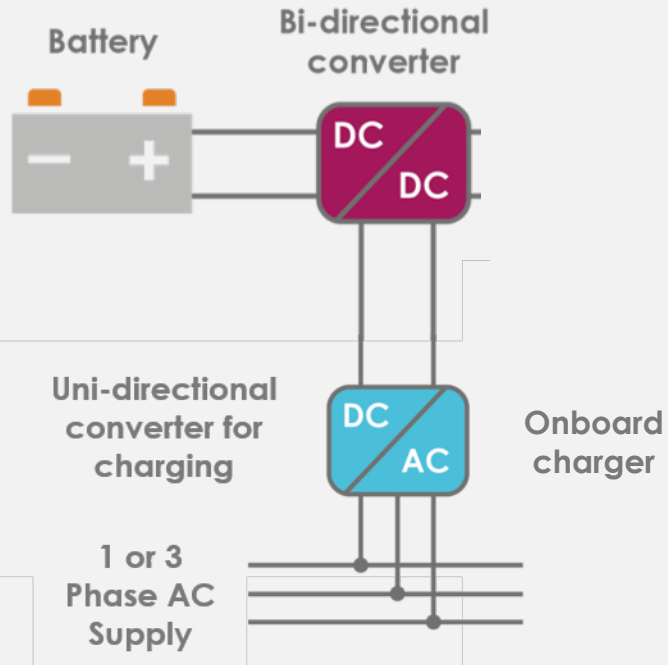

Electric car: Power flow

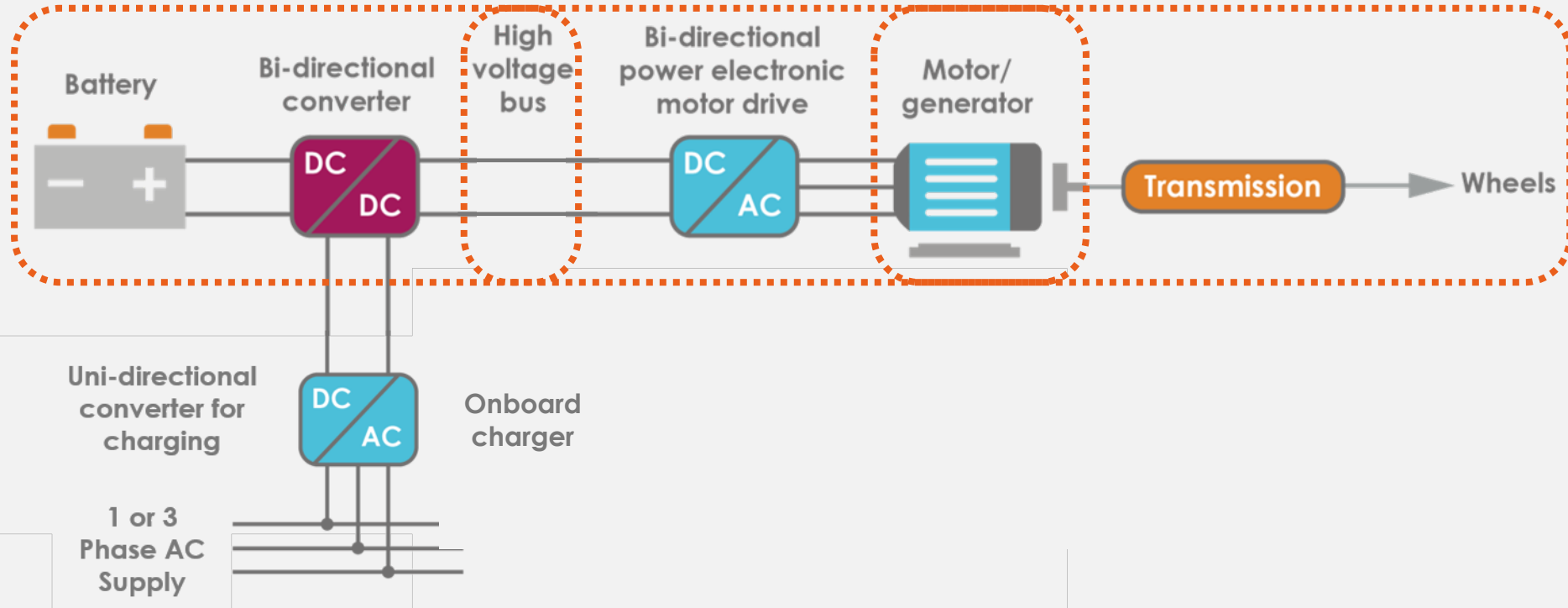

Electric car: Power flow

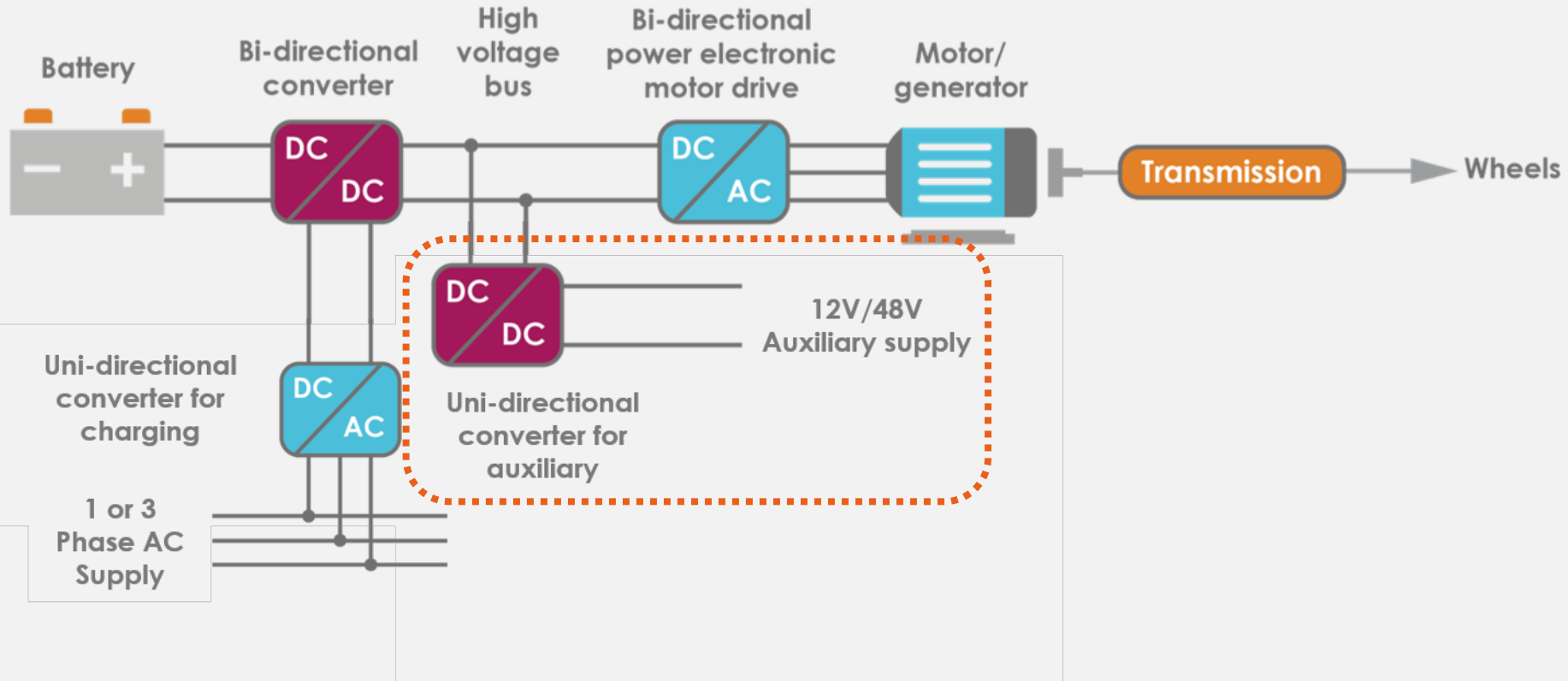

What's inside an electric car

Prof. Dr. Pavol Bauer, Delft University of Technology

