

PV Systems - Components and Concepts

Inverters in PV Systems

Week 7.4

Arno Smets, Nishant Narayan

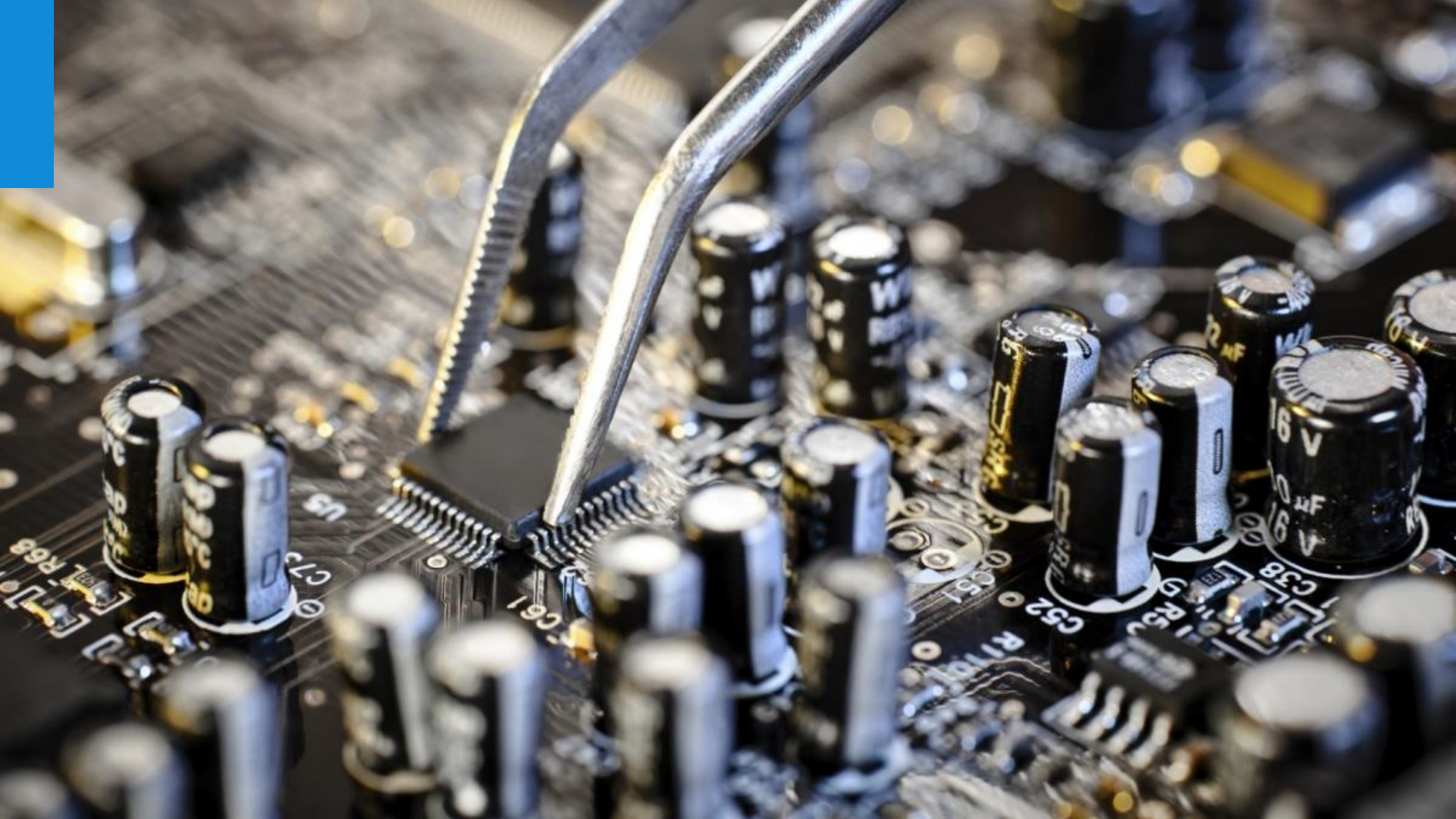

DC and AC current

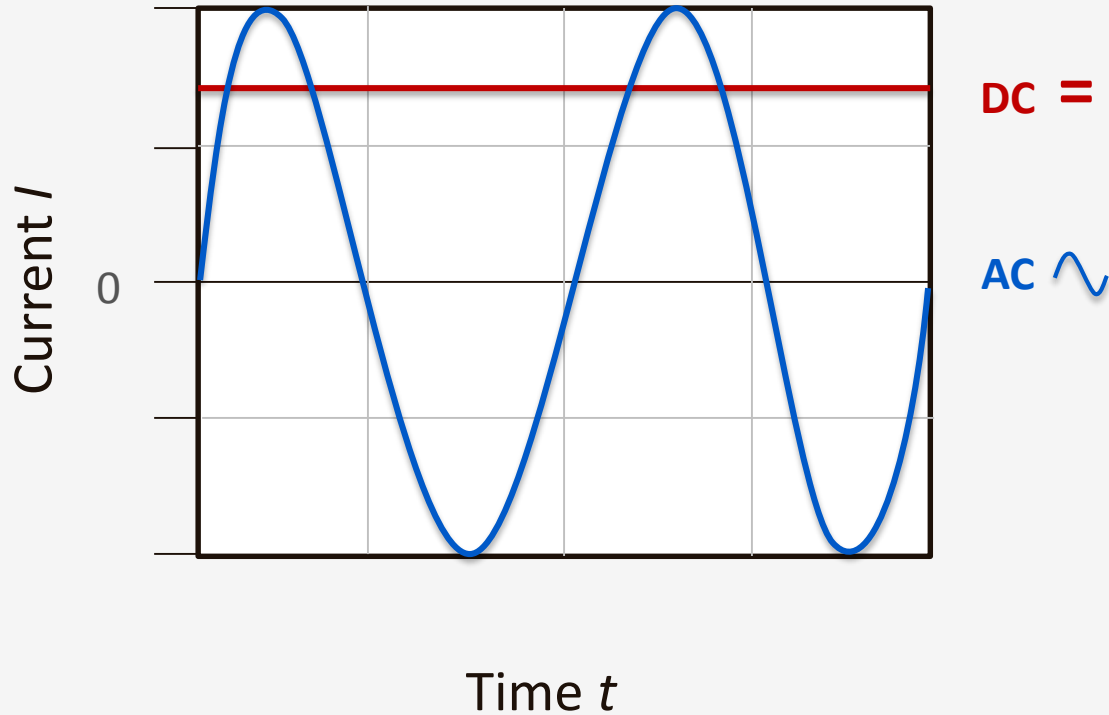



Inverter

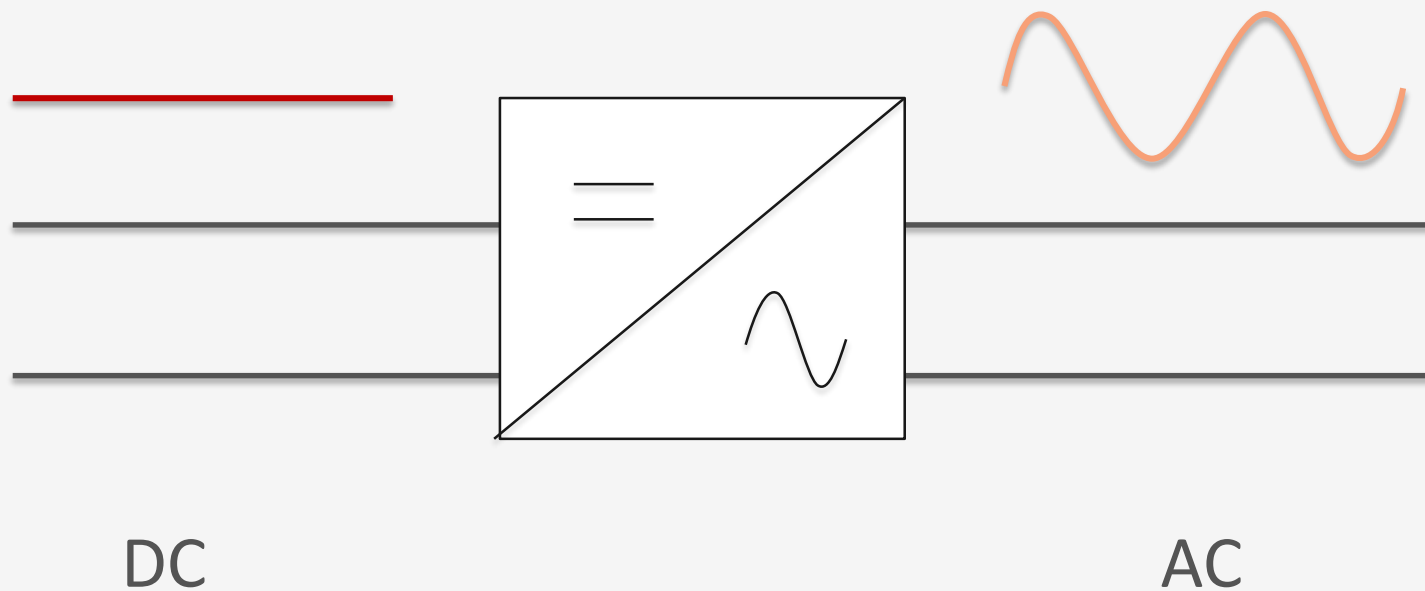

Stand-alone PV System

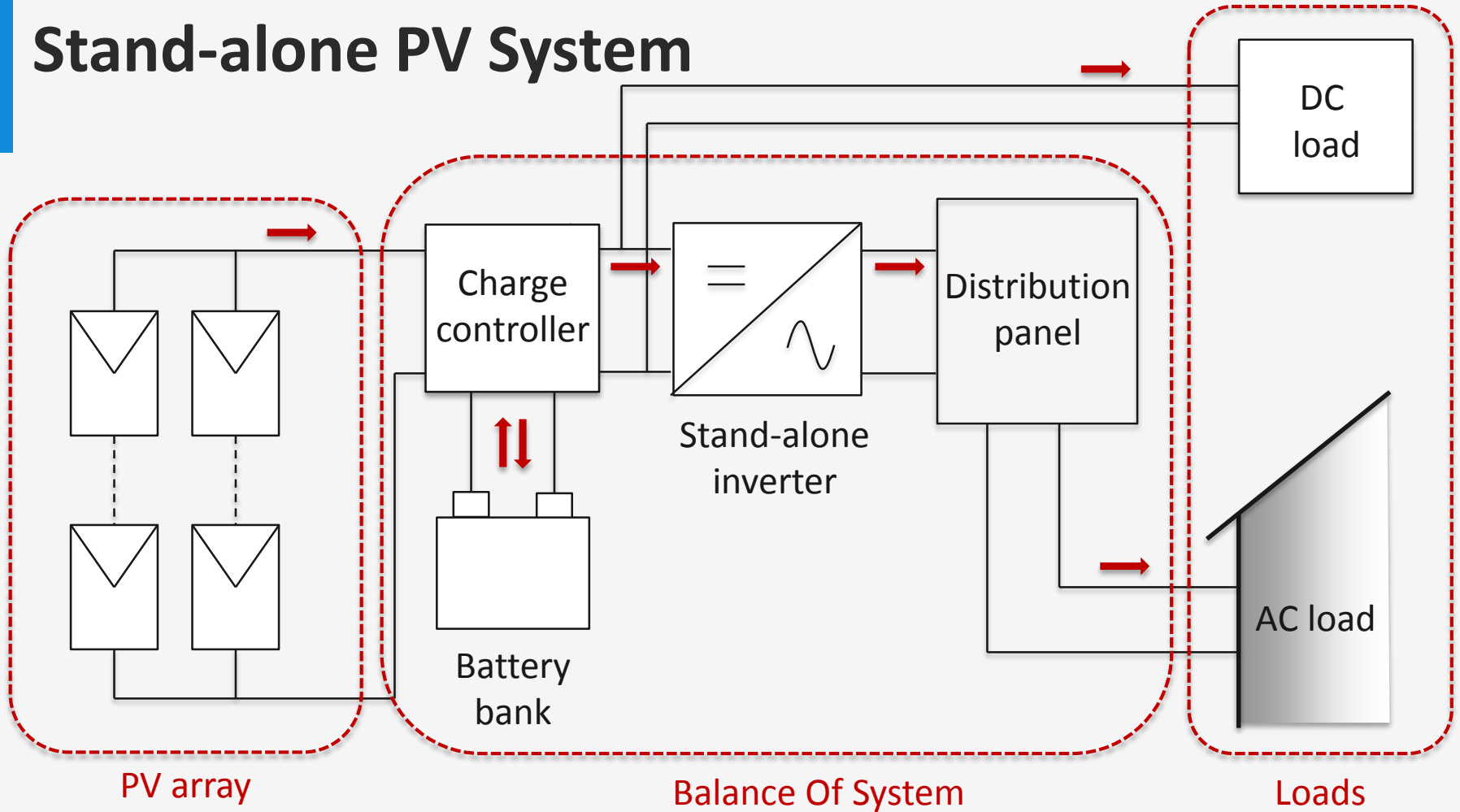

Grid connected system

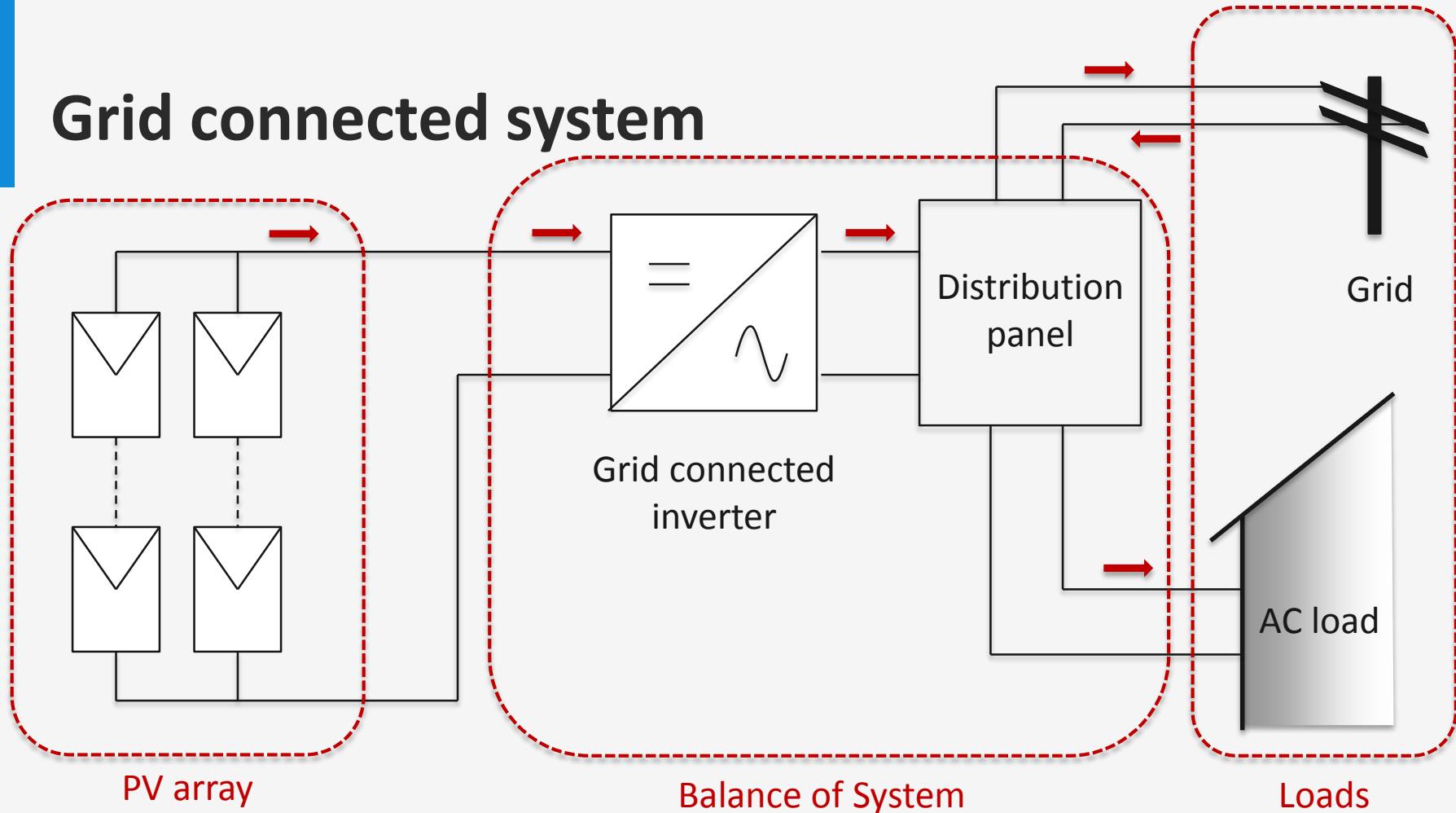

Hybrid PV System

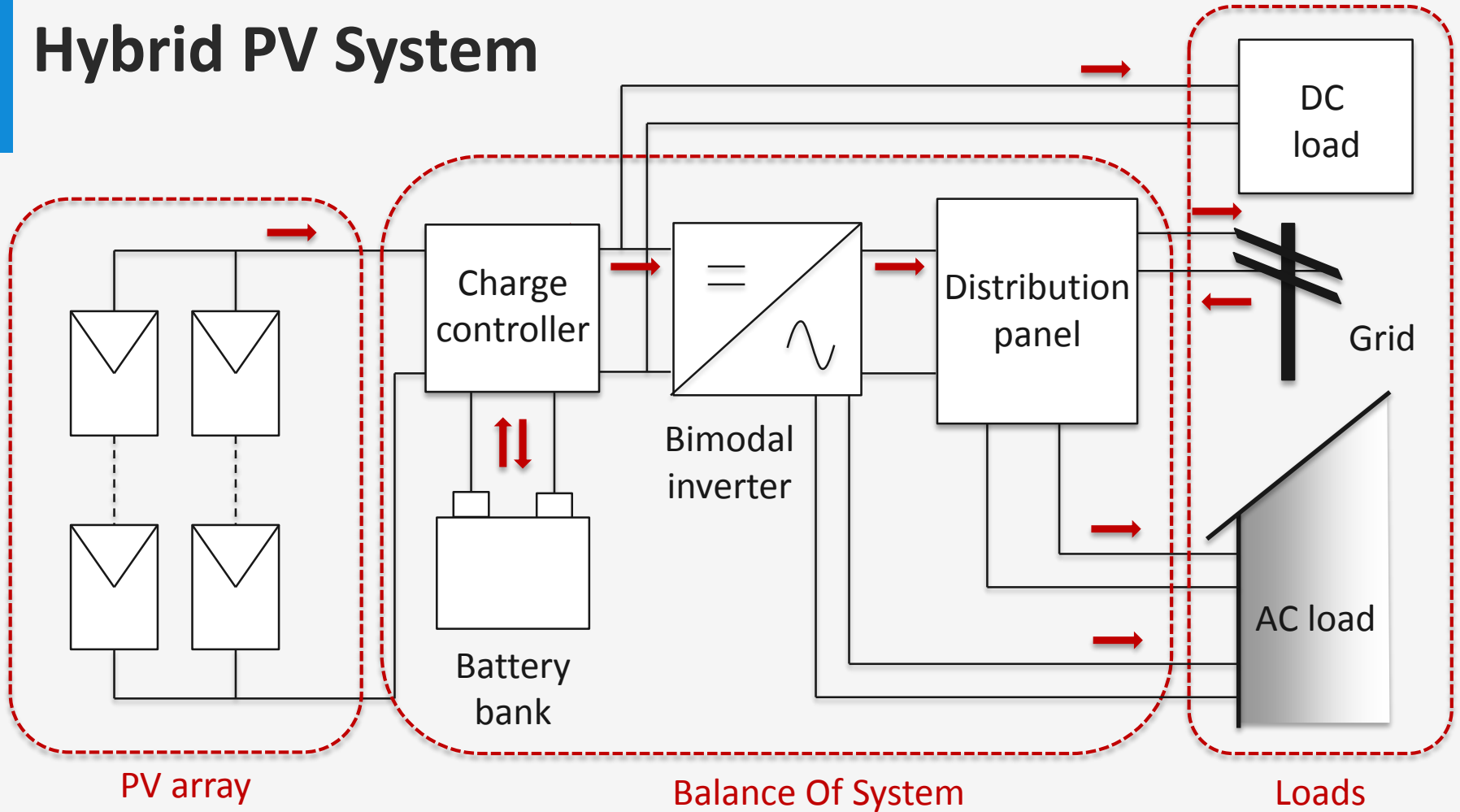

Generic I-V curve of a solar cell

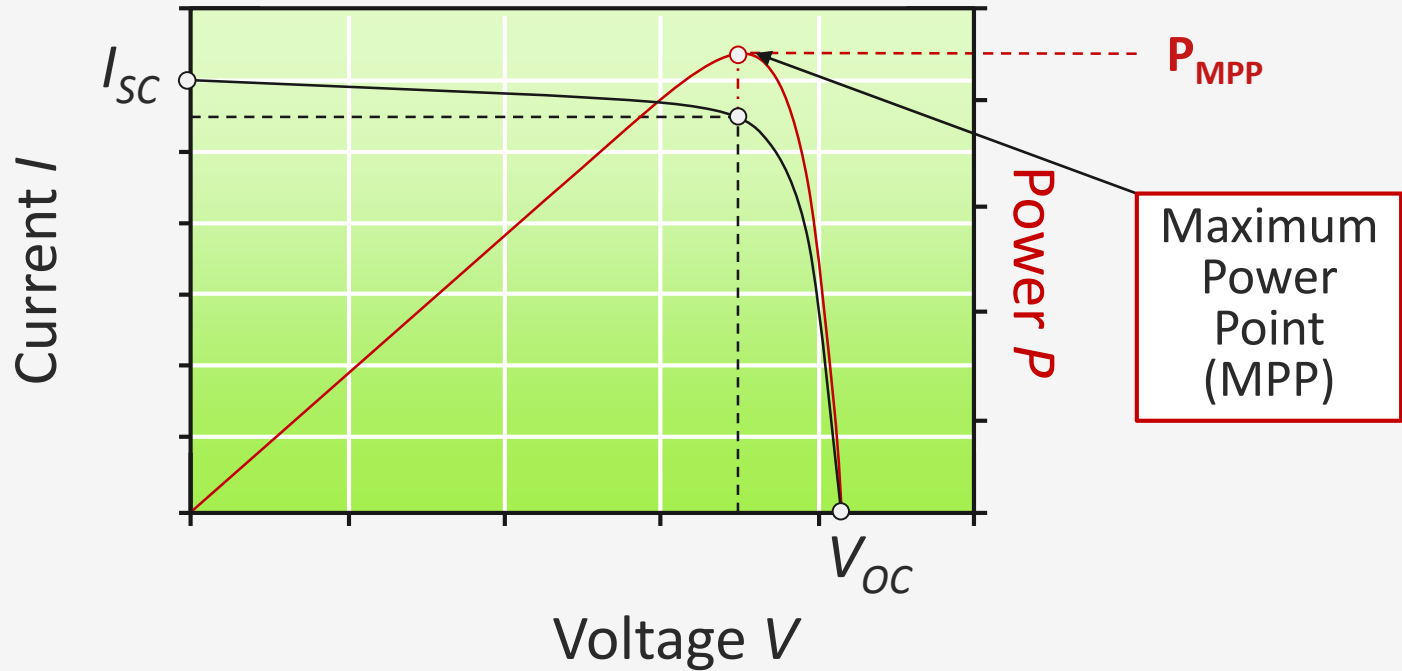

Implementation topologies

Central inverter

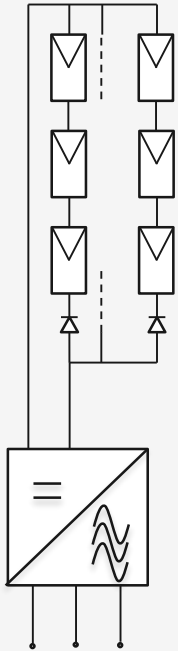

Module inverter

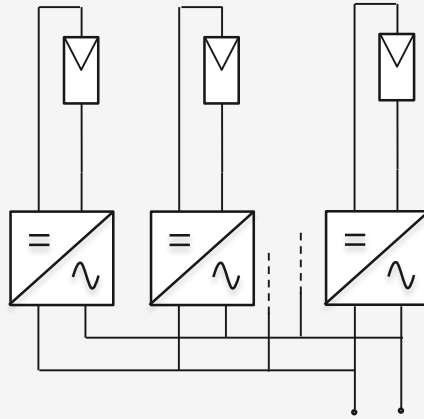

String inverter

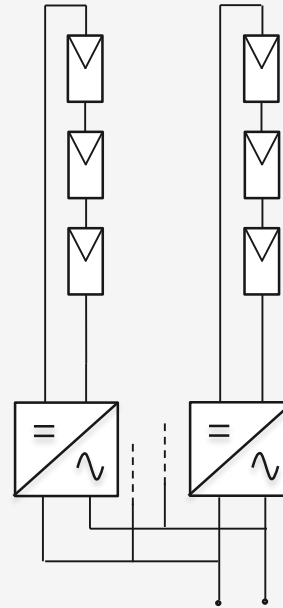

Multi-string inverter

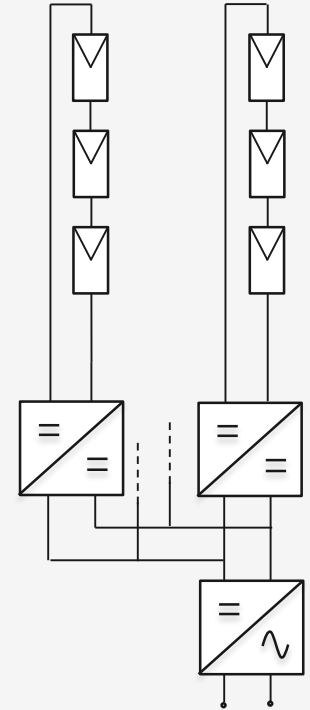

Central inverter

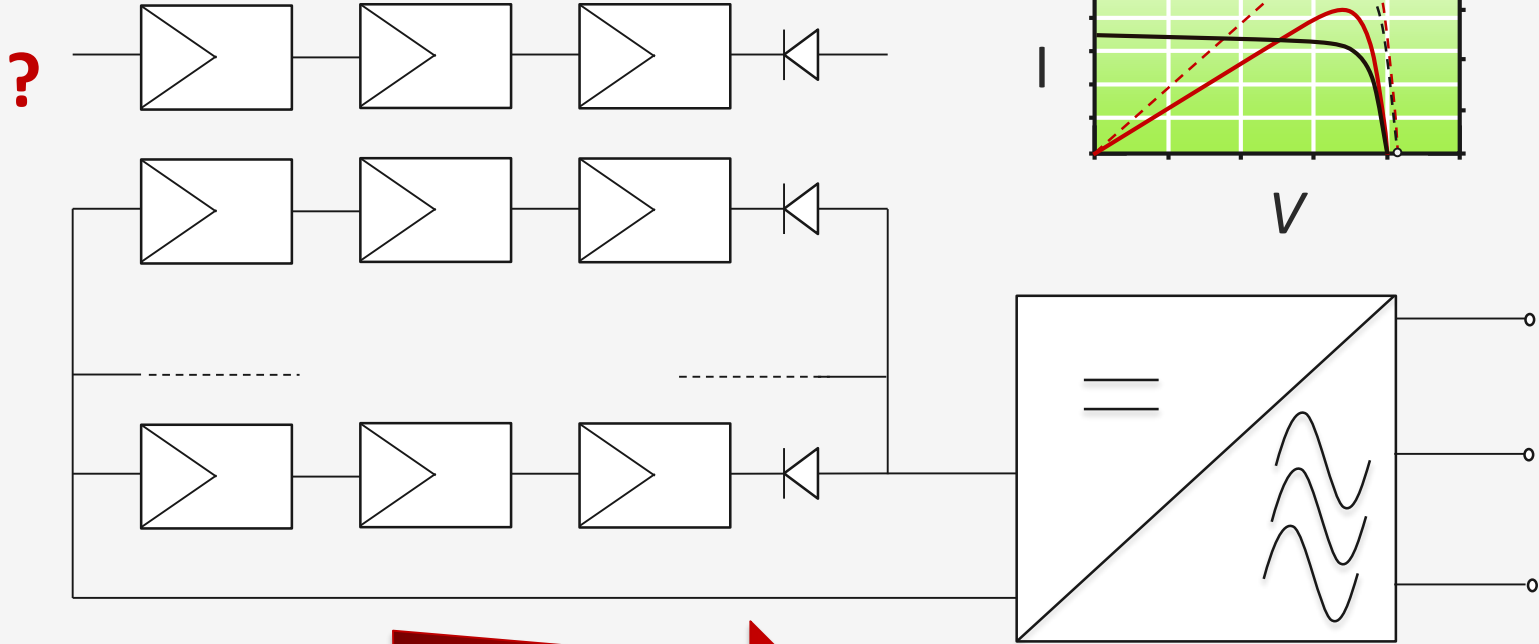

Module inverter

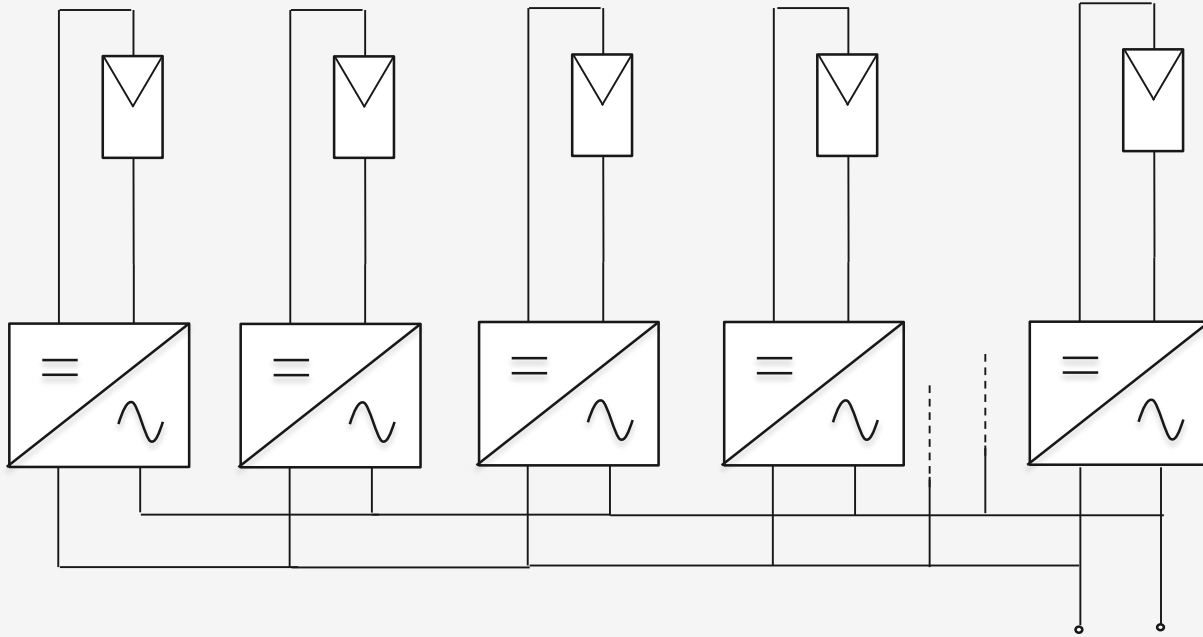

String inverter

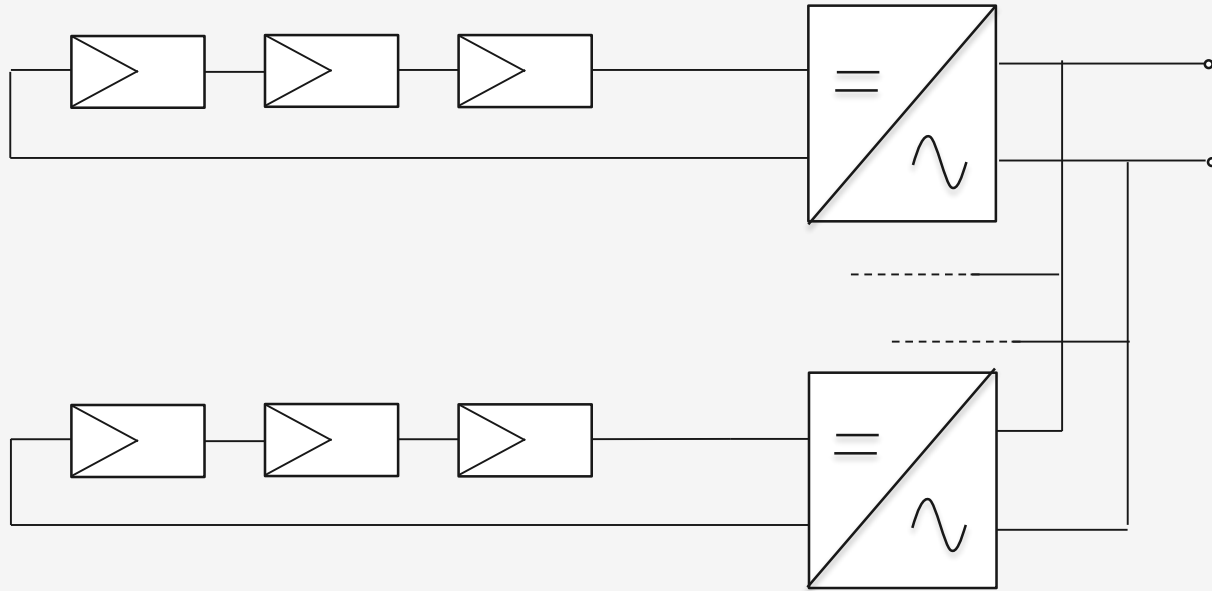

Multi-string inverter

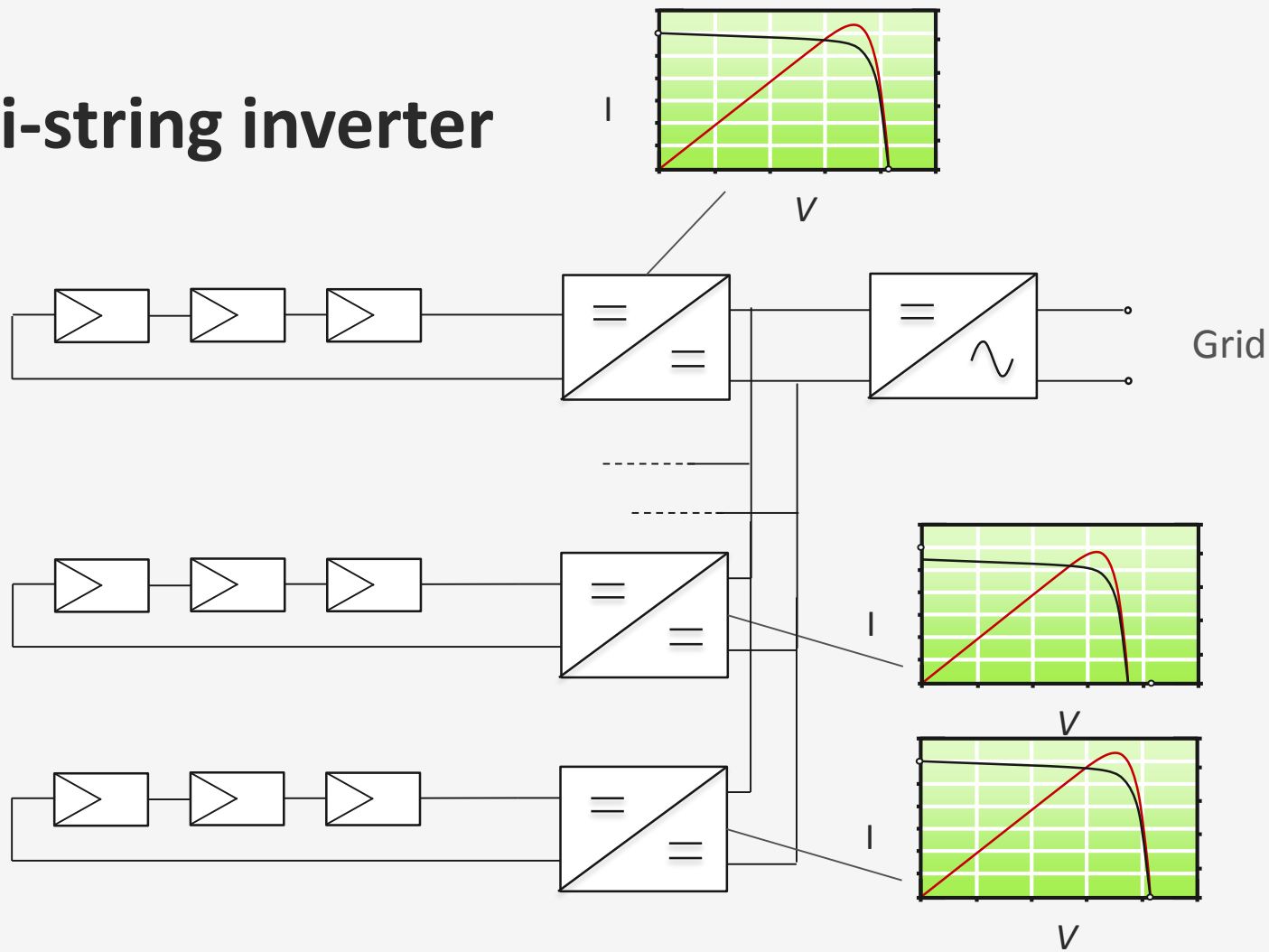

Characteristics of a solar inverter



η

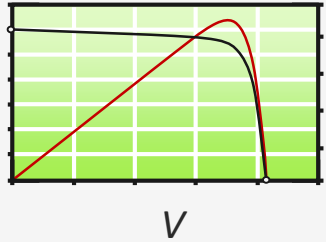

MPPT



T, H_2O

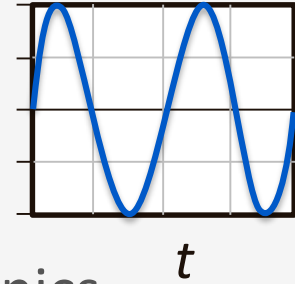

Low harmonics

Anti-Islanding

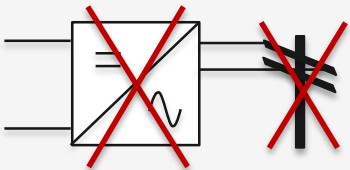

Lifespan





Thank you for your attention!