

# Working Principle of a Semiconductor Based Solar Cell

## Semiconductor Junction I - Basic Principles

*Week 2.4.1*

Arno Smets

# Semiconductor Junction

Band diagram

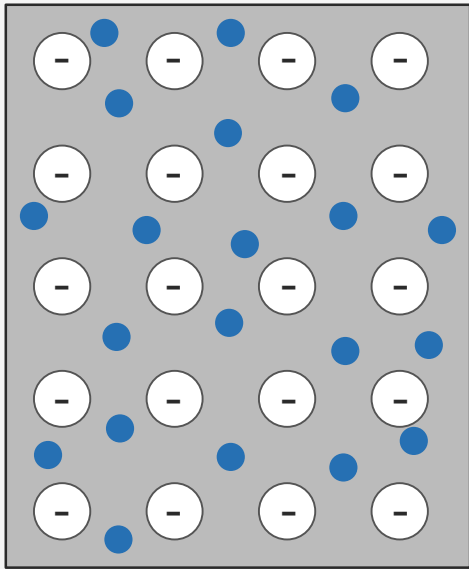
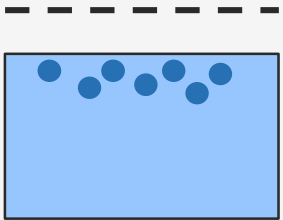
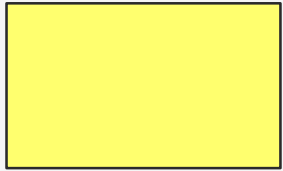

p region

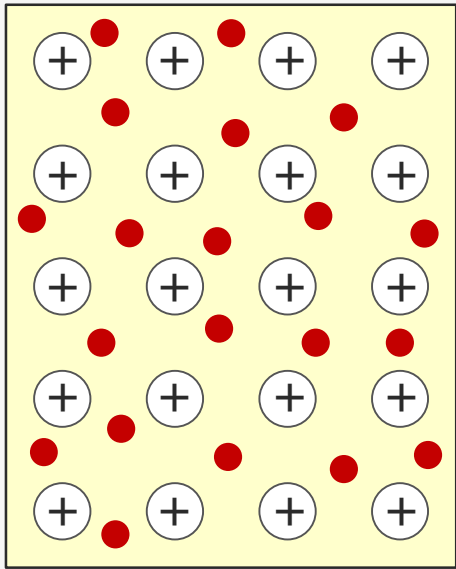

n region

Band diagram

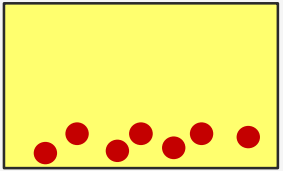

# Semiconductor Junction

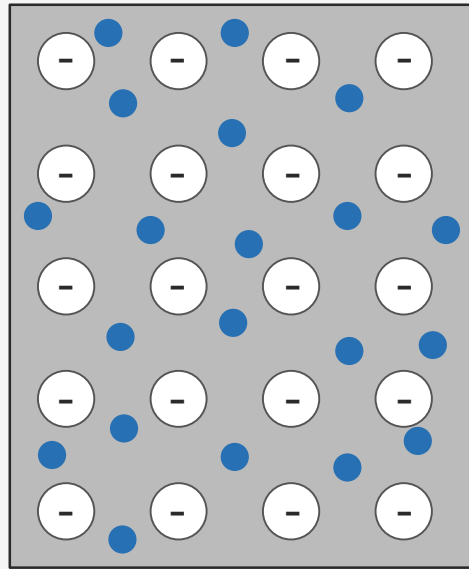

p region

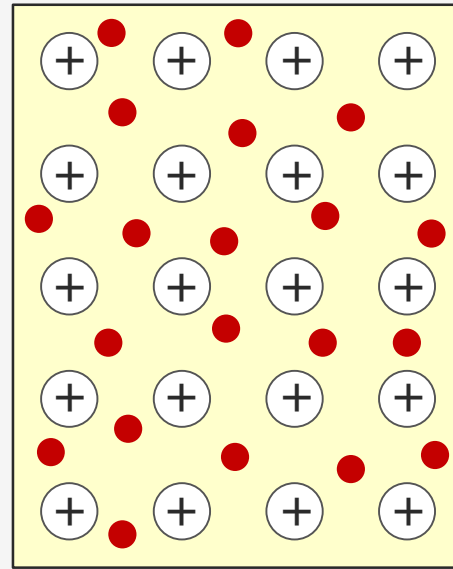

n region

# Semiconductor Junction

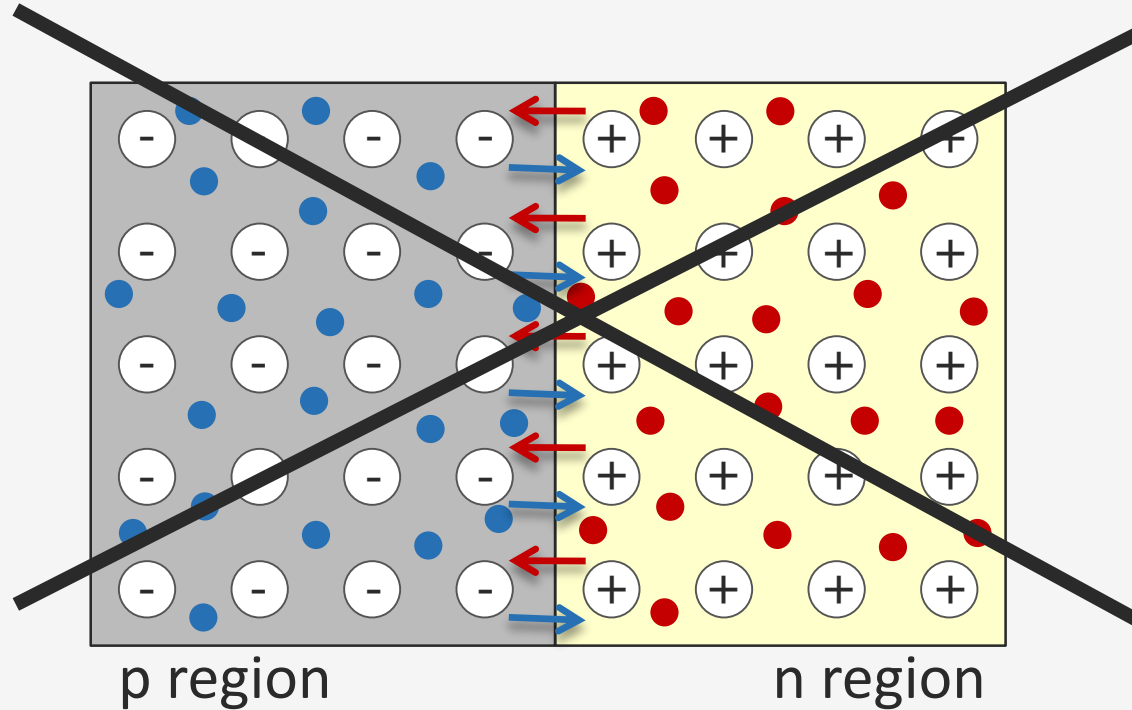

# Semiconductor Junction

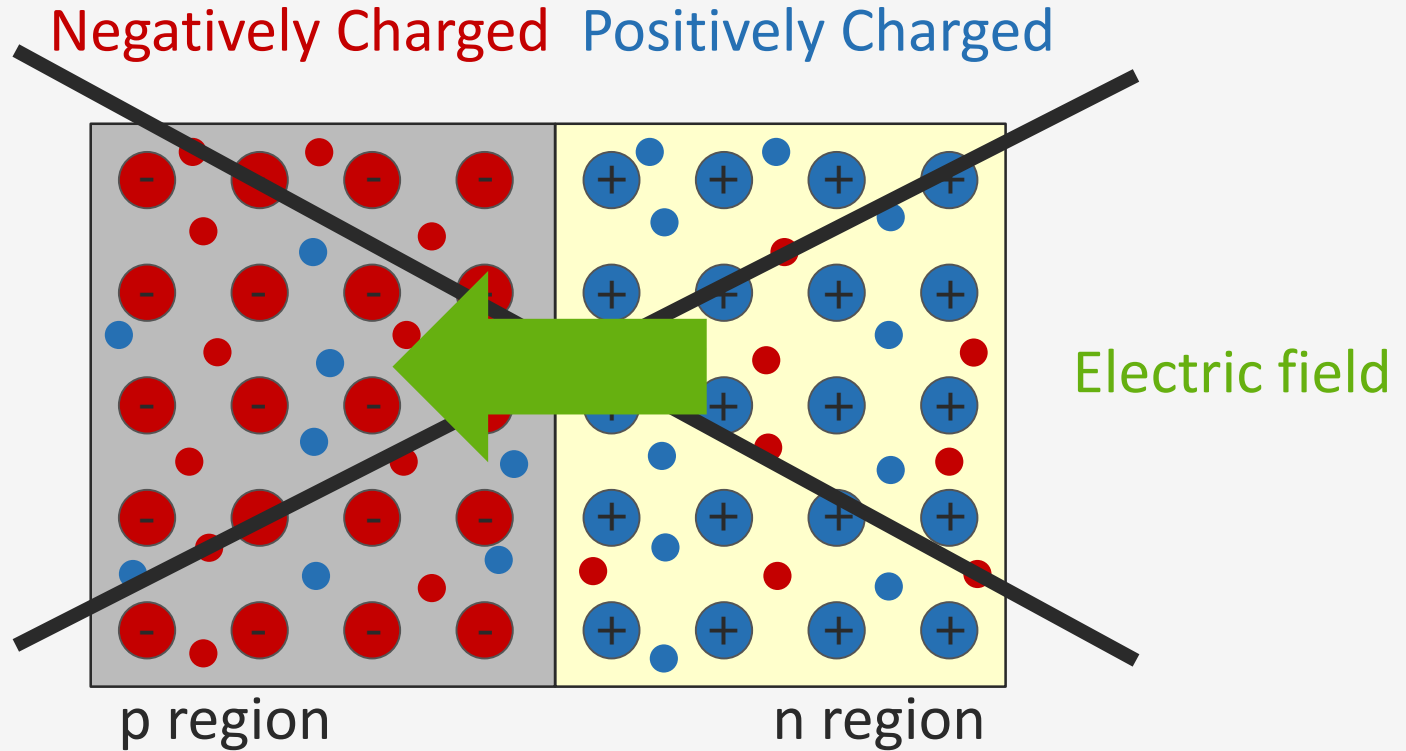

# Semiconductor Junction

*Diffusion of holes and electrons close to the junction*

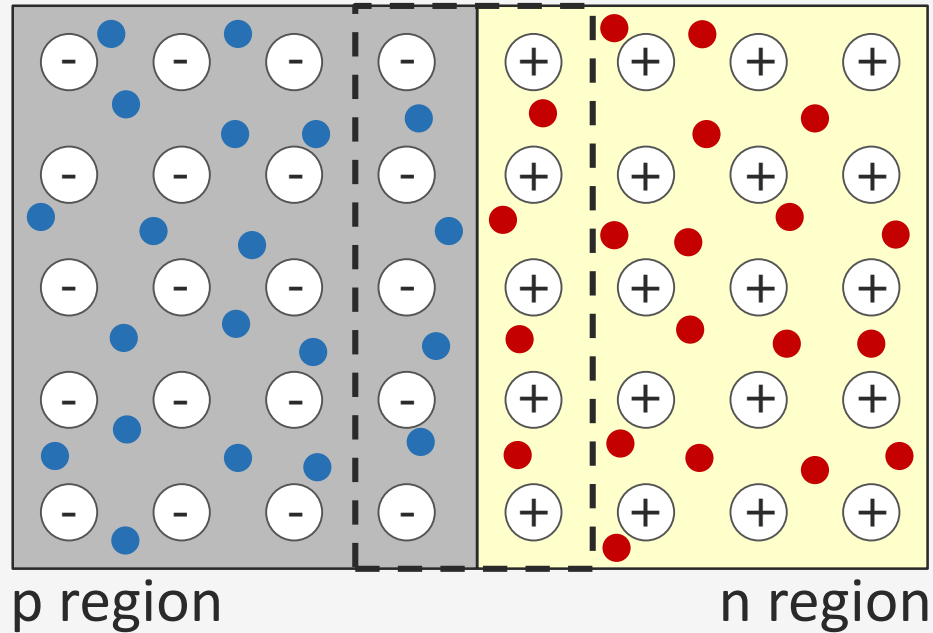

# Semiconductor Junction

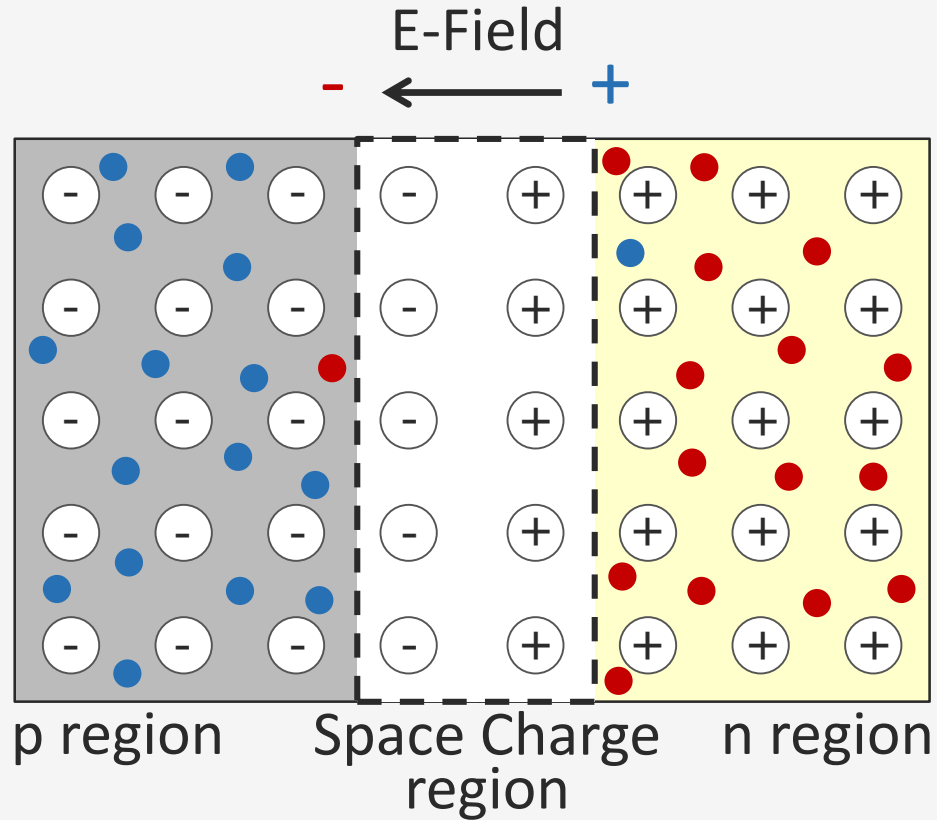

# Semiconductor Junction – Thermal Equilibrium

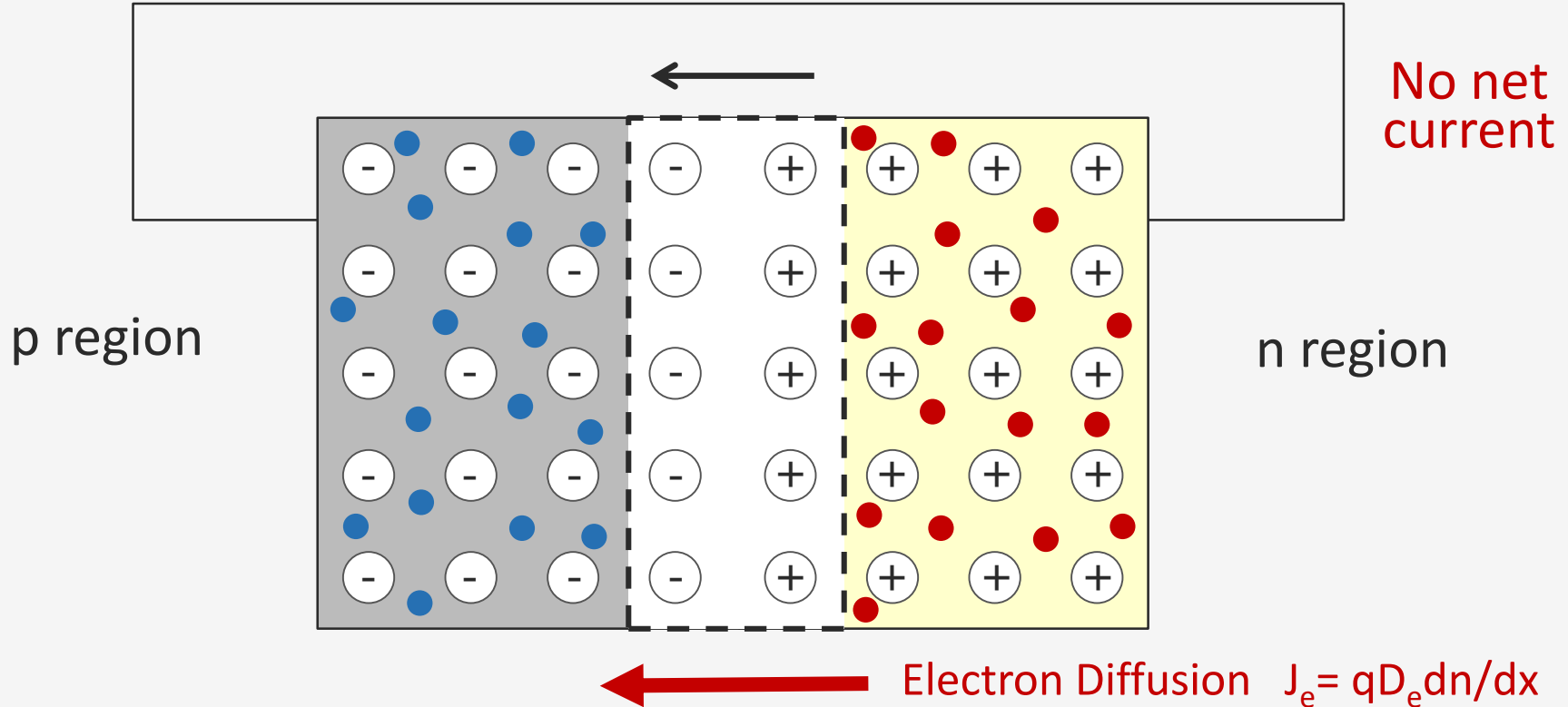



# Semiconductor Junction – Thermal Equilibrium

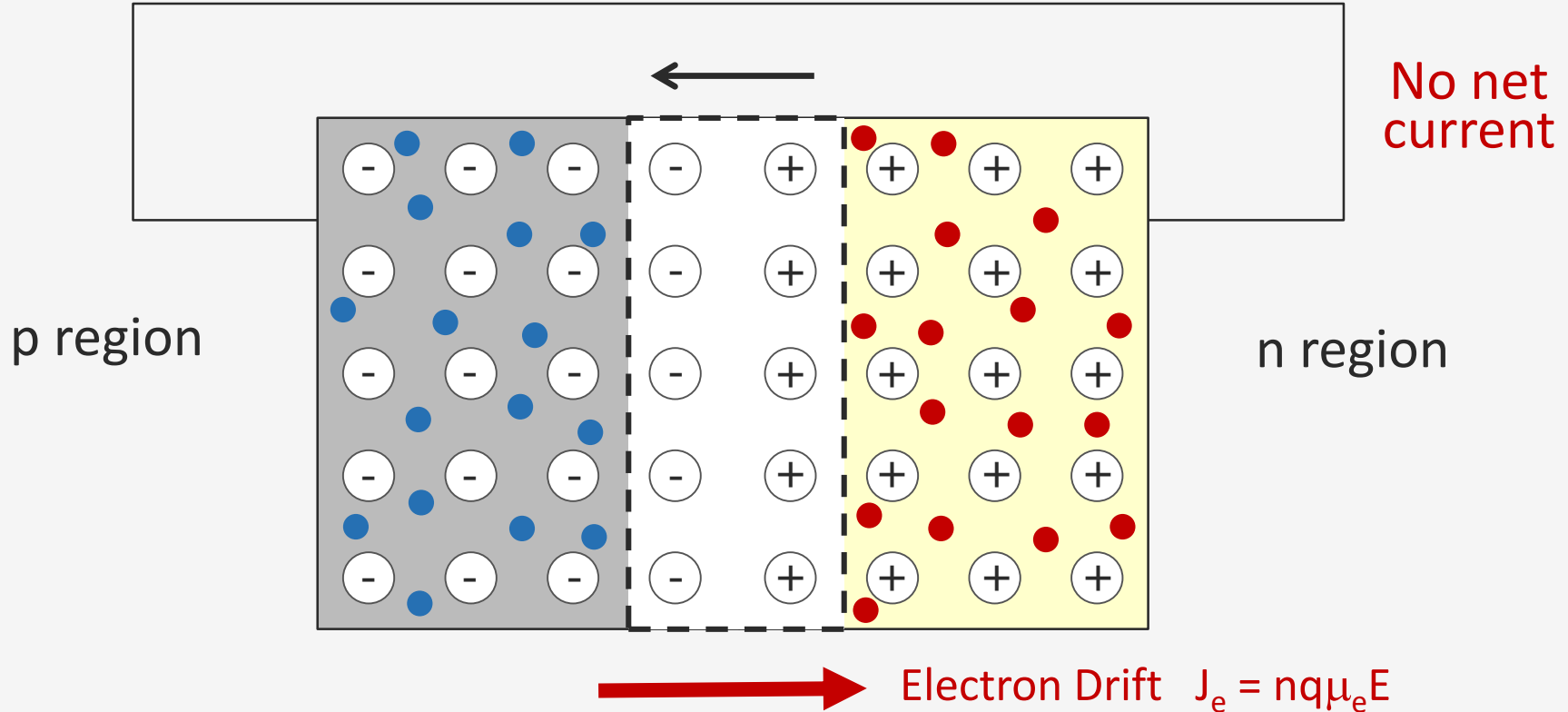

# Semiconductor Junction – Thermal Equilibrium

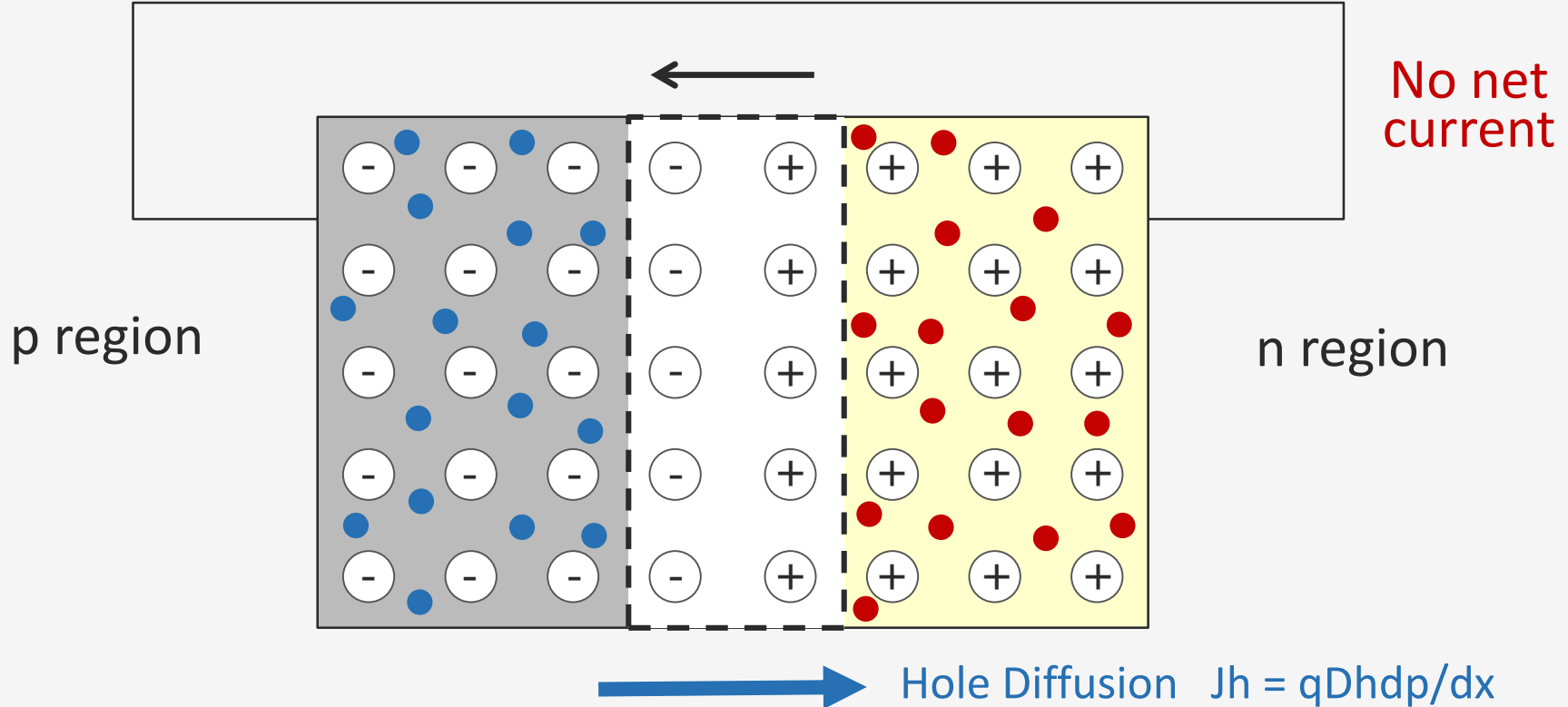

# Semiconductor Junction – Thermal Equilibrium

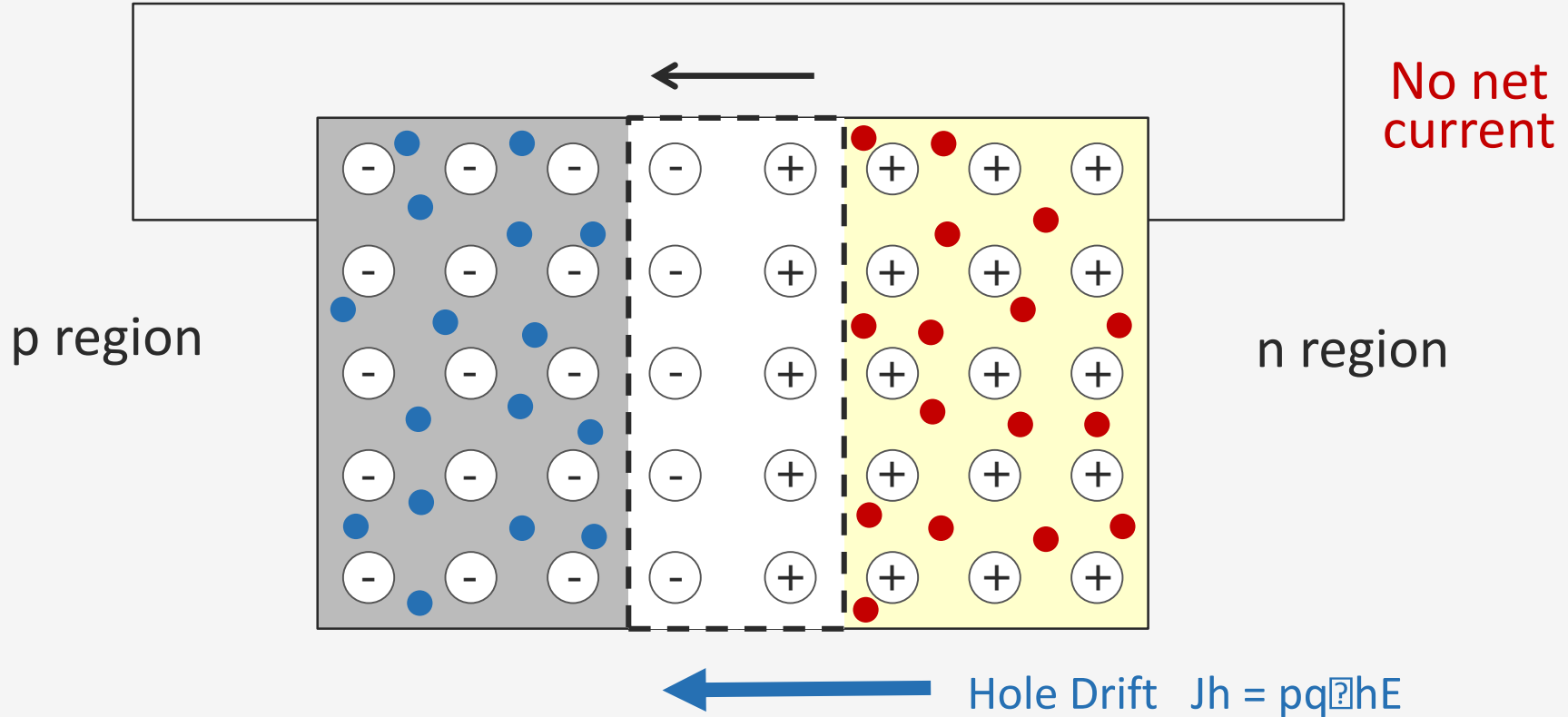

# Semiconductor Junction – Thermal Equilibrium

Potential energy of water level  $\sim$  Fermi level

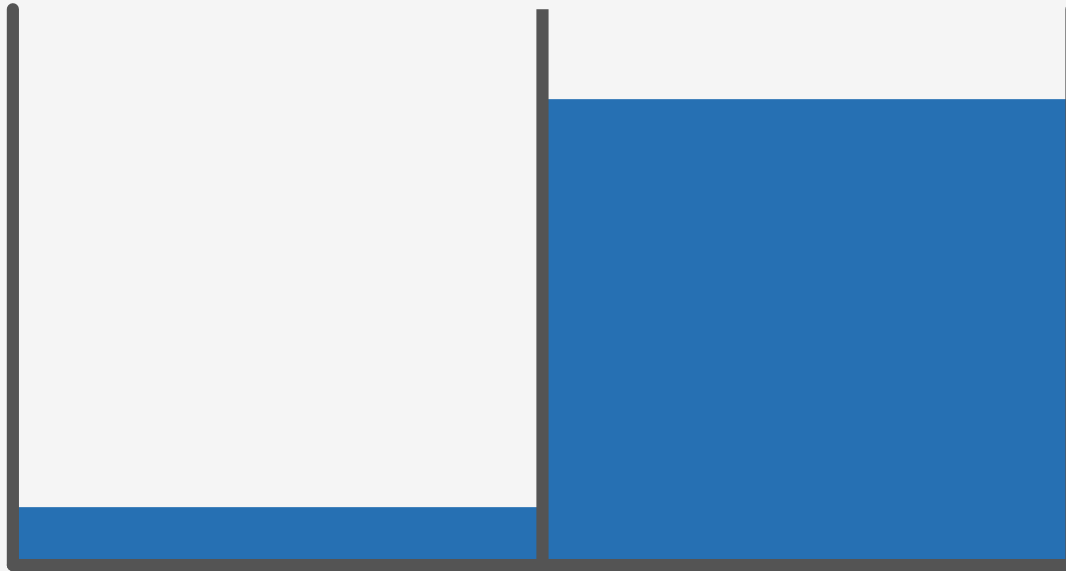

# Semiconductor Junction – Band diagram

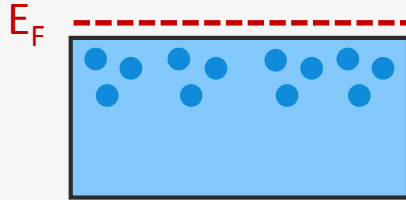
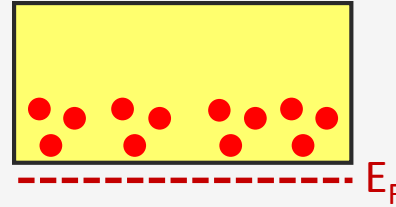

p-type



n-type

# Semiconductor Junction – Band diagram

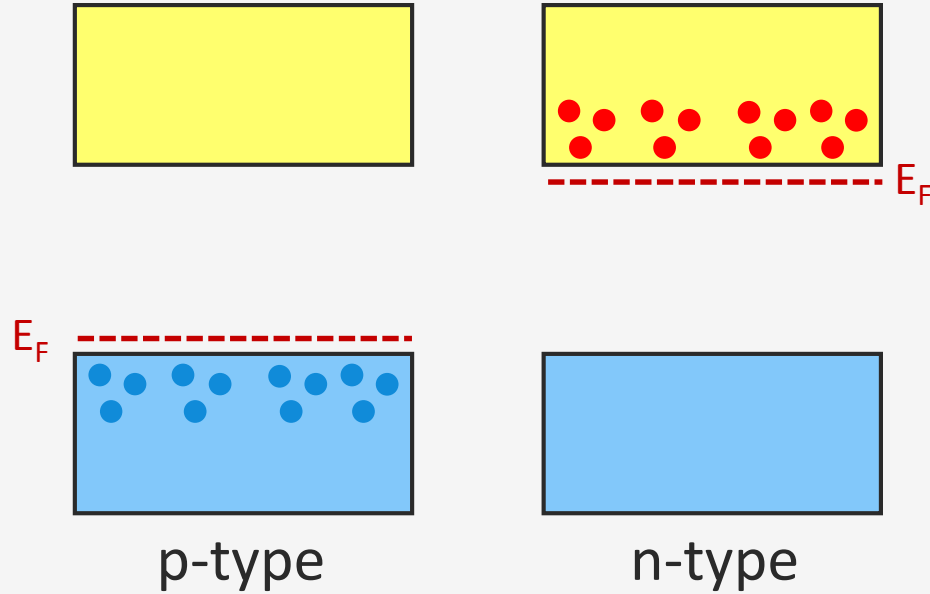

# Semiconductor Junction – Band diagram

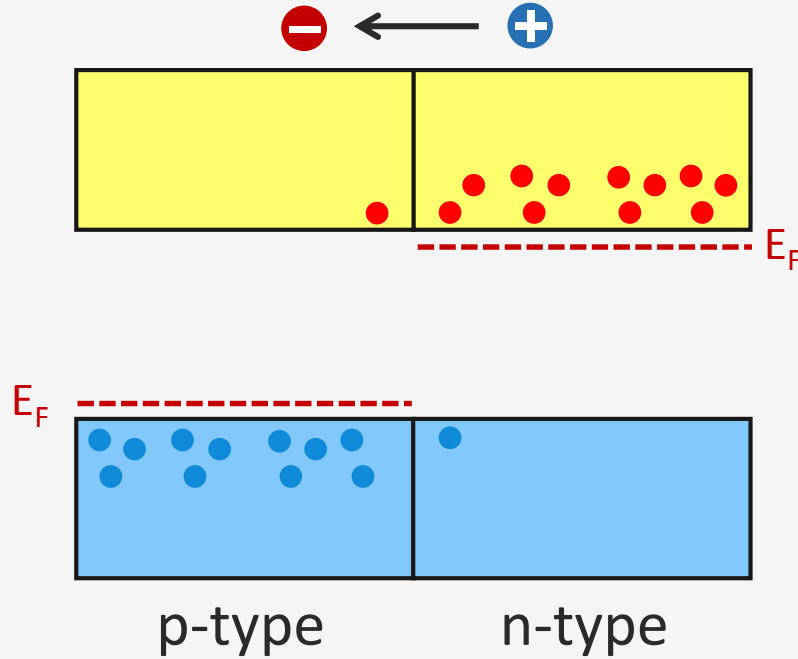

# Semiconductor Junction – Band diagram

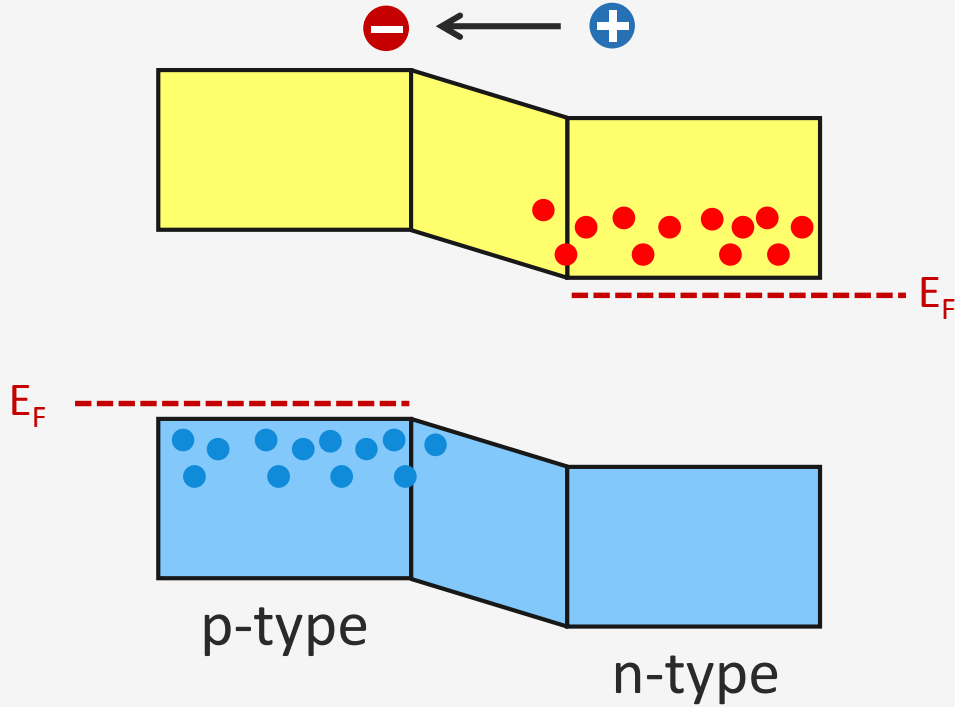



# Semiconductor Junction – Band diagram

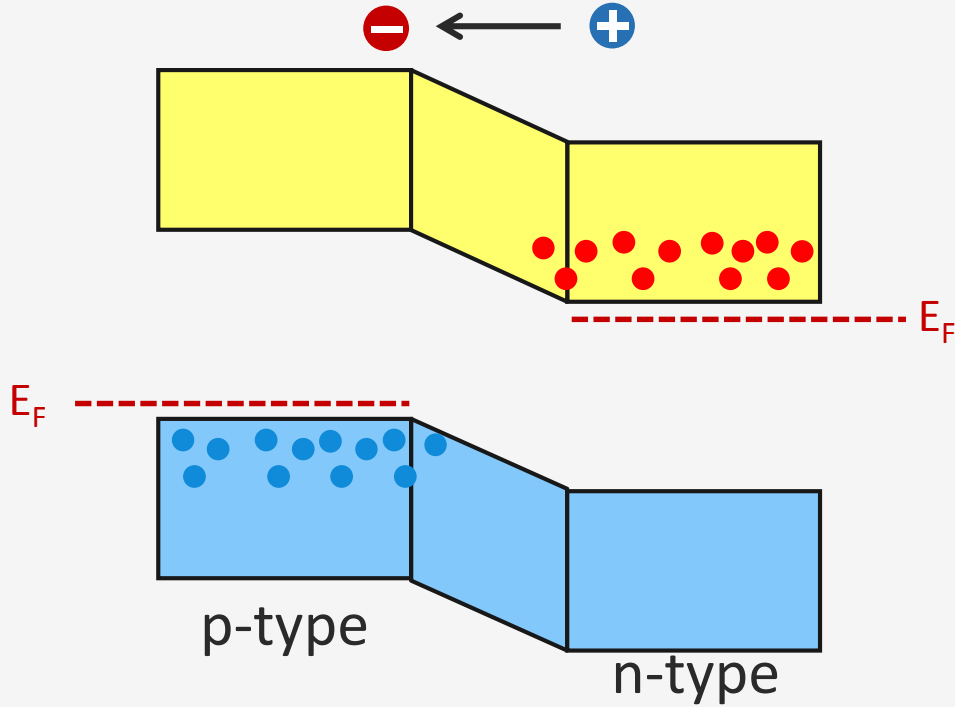

# Semiconductor Junction – Band diagram

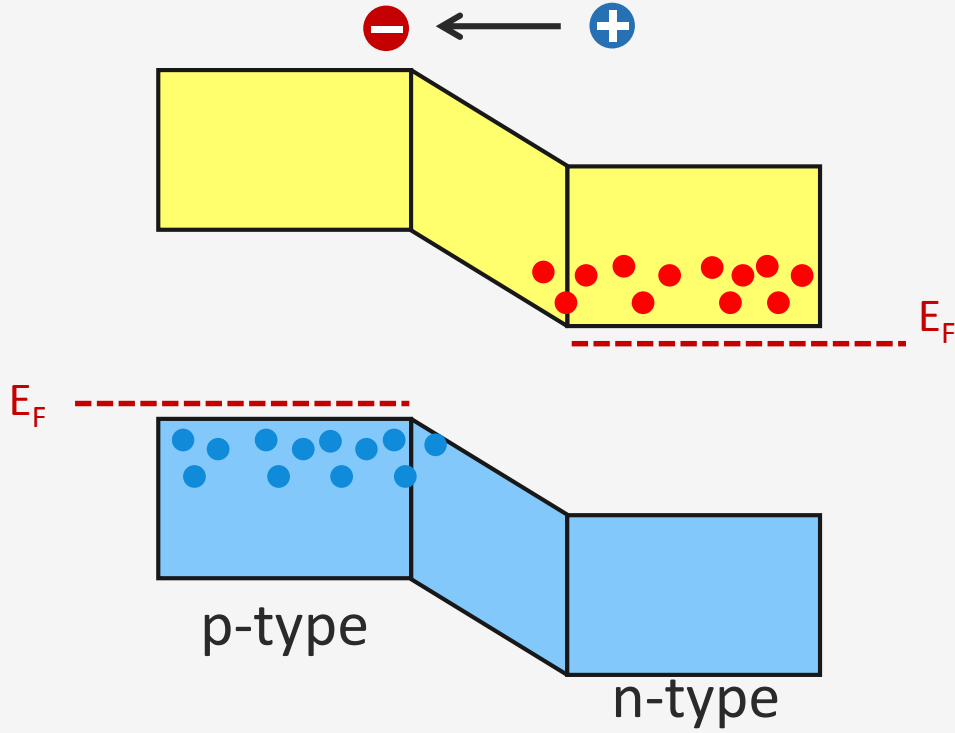

# Semiconductor Junction – Band diagram

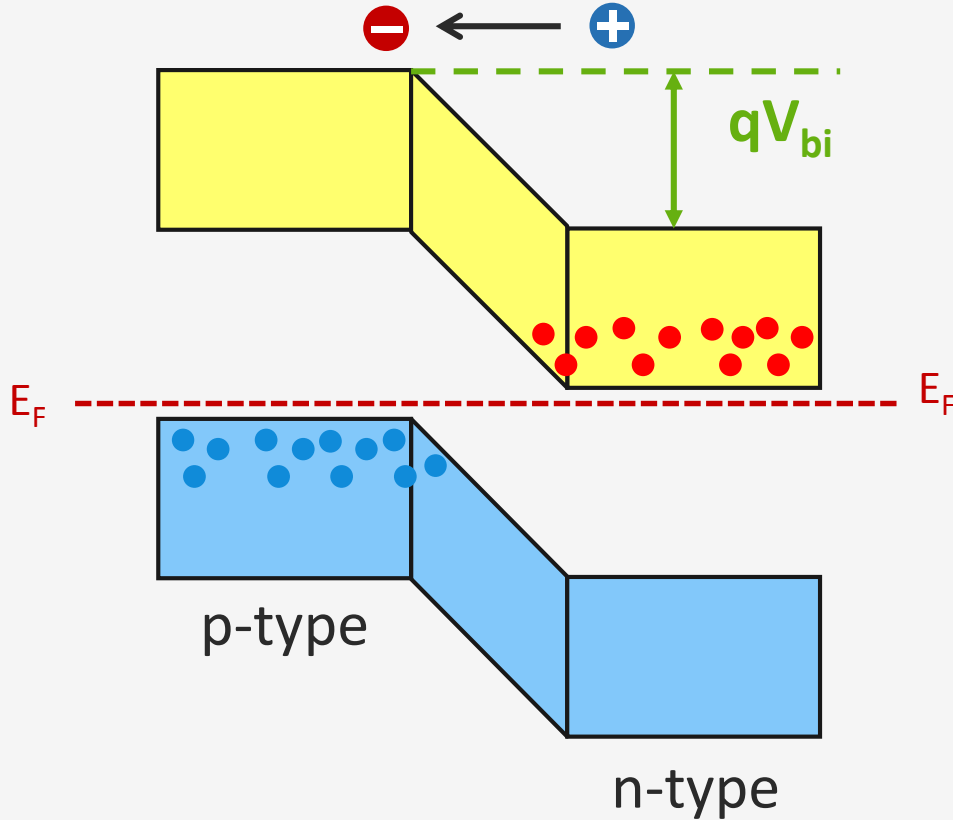

# Semiconductor Junction – Band diagram

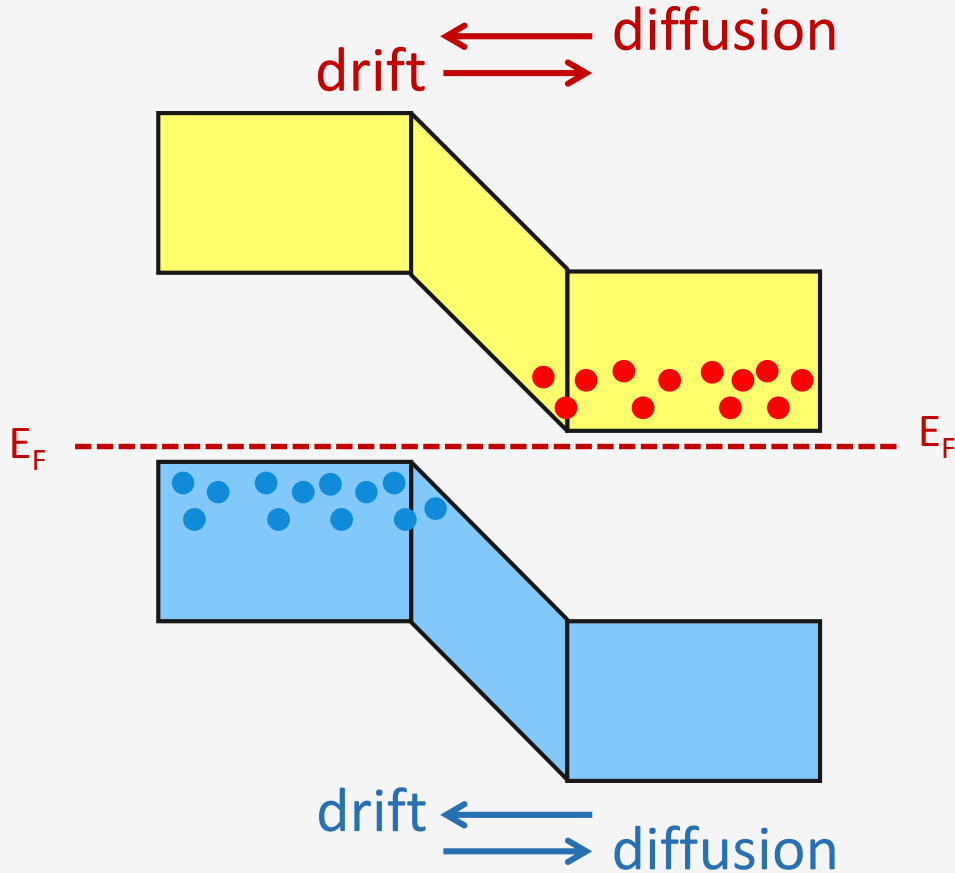

**Thank you for your attention!**